

PROMOTECH®

WELDING



WELDING



CUTTING



CUTTING



*smart tools
for heavy tasks*

**WELDING & CUTTING
TRACTORS**

CATALOGUE

PROMOTECH – PROFESSIONAL MANUFACTURER OF PREMIUM MACHINES FOR METALWORKING INDUSTRY

PROMOTECH is an innovation driven ISO 9001:2015 manufacturer of professional metalworking machines, welding automation equipment and industrial systems designed for structural steel fabricators, heavy machinery manufacturers, shipyards and other metal machining companies

Main product lines:

- mag drills, pneumatic drills, rail drills and hydraulic punchers
- weld preparation/portable and stationary bevellers for plates and pipes
- welding and cutting portable mechanisation equipment
- welding and cutting automated systems

Our products:

- offer solutions to reduce cost and increase productivity
- are designed and engineered for long term use in tough industrial conditions
- meet the requirements of the most demanding clients and markets worldwide
- are made in Poland according to the highest quality standards
- include top quality components
- are thoroughly tested for quality approval
- proved to be extremely reliable with a variety of practical applications in most difficult climatic environments



FOLLOW US FOR UPDATE AND MORE

TABLE OF CONTENT

<i>TRACTORS</i>	<i>PAGE</i>
MANTIS BATTERY	3
MINI SPIDER BATTERY	4
GECKO	6
GECKO BATTERY 2	8
SCORPIO BATTERY	10
OSC-8 PRO	15
LIZARD	18
RAIL BULL	22
RAIL TUG	24
RAIL TITAN 2	26
VACUUM TRACK SYSTEM	31
DRAGON, DRAGON HS, DRAGON BATTERY	33
OSC-8 PRO	32

**WELDING & CUTTING
TRACTORS**

pages
1-36



WELDING AND CUTTING TRACTORS



MANTIS BATTERY



MINI SPIDER BATTERY



GECKO



GECKO BATTERY 2



LIZARD



SCORPIO BATTERY



RAIL TUG



RAIL BULL

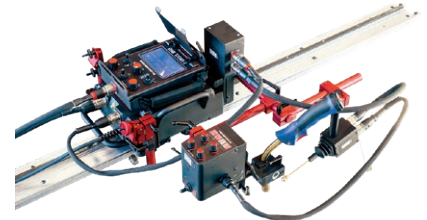

RAIL TITAN 2



OSC-8 PRO



VACUUM TRACK SYSTEM



DRAGON



DRAGON HS

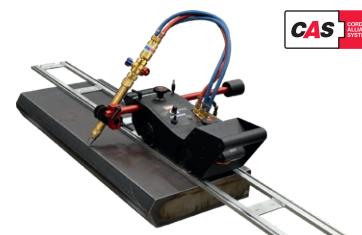

DRAGON BATTERY

All information is subject to change without notice. 26.03

MANTIS BATTERY | CORDLESS DUAL TORCH WELDING TRACTOR

Mantis Battery is a specialized welding tractor designed for precise and efficient welding of steel profiles used as reinforcement elements in various steel structures such as flat bars, angle profiles (L), T-bars, bulb flats (often referred to as „bulb profiles“), I-beams or H-beams and channels (C-profiles).

The tractor allows operation with two torches simultaneously in continuous or intermittent welding mode.

Its programming function allows you to set the desired welding path by specifying parameters such as weld length, skip length as well as crater filling at the beginning and the end of the welds.

18 V DC Lithium Ion High Density battery (LiHD) ensures extended power availability even for the whole shift (the same CAS battery as used in other PROMOTECH cordless machines).

Features & benefits:

- Battery-powered programmable welding tractor for travelling on steel profiles such as flats, angles, I-beams, T-beams, bulb flats and irregularly shaped work pieces with radius down to 160 mm
- Dual-sided operation with two torches in continuous or intermittent welding mode
- Simple and ergonomic programming of weld patterns and stitch welding parameters
- Multi-functional LED display showing travel speed, units, welding settings and diagnostic messages
- 18 V DC allows safe use of MANTIS Battery in harsh environments like shipyards that are often wet, metallic, and confined
- The LiHD battery, supported by intelligent battery management, ensures maximum power availability for an extended period
- Closed-loop speed control system stabilizes travel speed, enabling uniform heat input for consistently high-quality welds
- Compact, lightweight design with durable cast aluminium housing
- Operates at speeds from 5 to 130 cm/min
- Tractor travels at full speed between stitches, which saves valuable welding time
- No need for mains power and one less cable to carry around

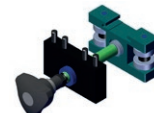
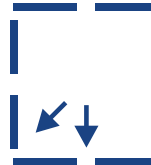
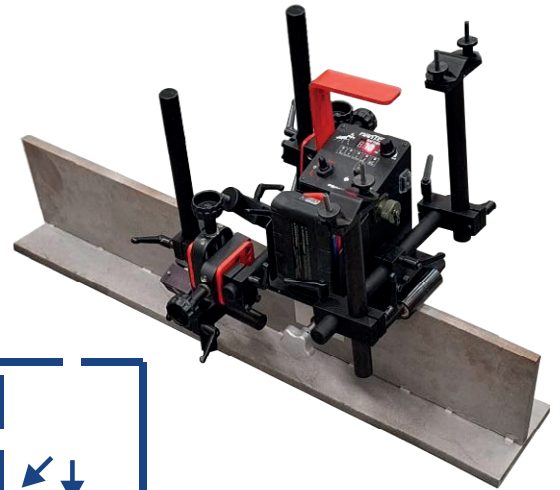

Klemme für Flacheisen (Option)
DCS-0824-0037-00-0

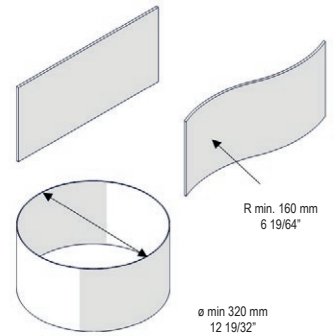

Clamp for T profiles and angle profiles (option)
DCS-0824-0037-01-0

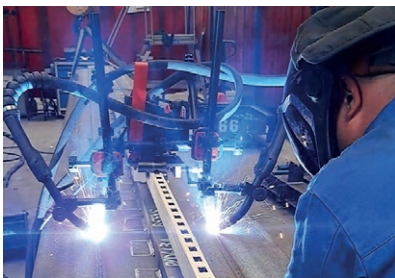
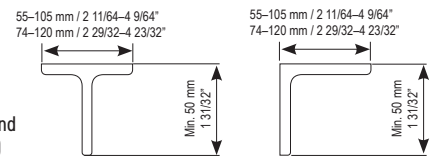

Small clamp for bulb profiles
50-180 mm (option)
DCS-0824-0037-02-0

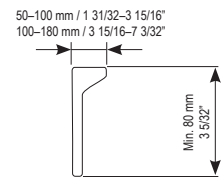

Large clamp for bulb profiles
200 - 340 mm (option)
DCS-0824-0037-03-0

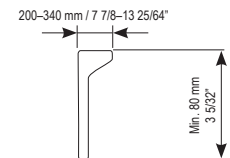

MANTIS BATTERY TECHNICAL SPECIFICATION		
Voltage	18 V DC, 4 Ah	
Power	18 W	
Welding position (according to EN ISO 6947 and AWS/ASME)	Horizontal	PA/1F/1G PB/2F
Torch type	MIG/MAG	
Torch diameter	16-22 mm (5/8"-55/64") up to 35 mm (1.38") option	
Horizontal pulling force	150 N	
Cross slide adjustment range	0-35 mm (0-1 3/8"), up-down, left-right	
Horizontal speed	5-130 cm/min	
Weight (without the battery)	7 kg (15.4 lbs)	
Product code	WOZ-0824-10-18-00-0	

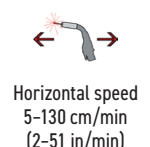

BOOST YOUR MOBILITY WITH BATTERY POWER!
No need for power cables





MINI SPIDER BATTERY

CORDLESS WELDING TRACTOR

The MINI SPIDER Battery is a battery-powered welding tractor designed to produce continuous fillet welds using MIG/MAG torches. The CAS LiHD (High Density Lithium Ion) battery provides sufficient power for handling even the toughest applications without the need for cables. The 4-wheel drive system and permanent magnetic base provide powerful traction and smooth travel. Travel speed control and stabilization enable precise matching of weld bead geometry to required specifications, reducing costly over-welding and significantly decreasing filler metal consumption. The torch can be swapped from one side of the MINI SPIDER Battery to another, enabling the operator to weld the entire workpiece from end to end.

Features and benefits:

- The compact and lightweight design facilitates welding in narrow spaces
- Convenient 18 V DC battery supply (same 4.0 Ah battery as other PROMOTECH battery-powered tractors)
- No need for mains power and one less cable to carry around
- Intelligent battery management for long-lasting performance
- Digital LED display for presetting of travel speed and diagnostic messages
- Easy access for battery charge level reading
- Built-in guide rollers with adjustable height
- Torch on the left or right side
- Welding edge to edge (e.g. welding of stiffeners for bridge structures)
- Consistent heat input reduces distortion

BOOST YOUR MOBILITY WITH BATTERY POWER!
No need for power cables

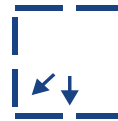
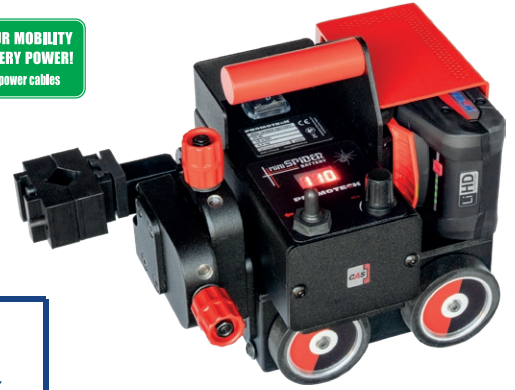

Control system of battery pack:

Detection and supervised parameters:

- too low and too high voltage
- too low and too high temperature
- failure of the temperature sensor
- internal battery failure

Benefits:

- over discharge protection
- extended battery life
- high level of safety for both tractor and operator



Torch on the left or right side

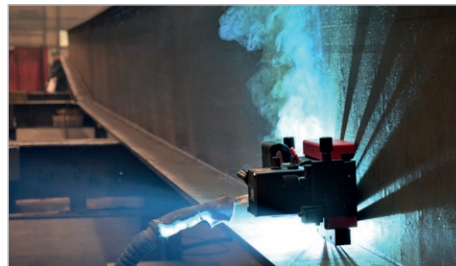

Welding edge to edge



Welding in narrow spaces (min. width 200 mm)

MINI SPIDER BATTERY TECHNICAL SPECIFICATION	
Voltage	18 V DC, 4.0 Ah
Power	25 W
Welding position (according to EN ISO 6947 and AWS/ASME)	PB / 2F PA / 1F
Torch diameter	16-22 mm (0.63-0.87")
Min. workpiece thickness	4 mm (0.16")
Ground clearance	4 mm (0.16")
Horizontal pulling force	150 N
Horizontal speed *	0-110 cm/min (0-43.3 in/min)
Cross slide adjustment range	0-21 mm (0-0.83") up down, left-right
Weight (w/o battery)	6.6 kg (14.6 lbs)
Product code	WOZ-0759-10-00-00-0

* With battery fully charged

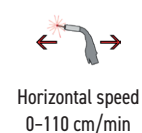



Horizontally laid control panel with display for easy reading and knob adjustment.
Side mounted battery for ergonomic handling with easier access for battery charge level reading.



Specially designed shielding with an undercut that facilitates multi-pass welding and significantly reduces the risk of collisions.

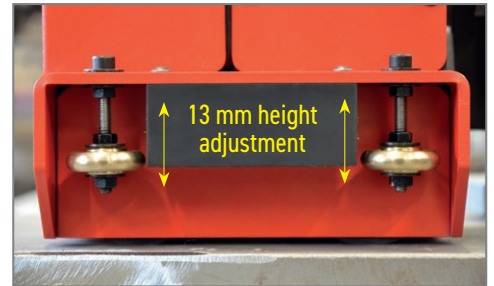

Height-adjustable guide rollers in a range of 13 mm.

Standard accessories:



Battery 4.0 Ah
AKM-0738-10-00-01-0
(2 pcs included)



Quick-release torch clip
16-22 mm
ZCS-0270-42-00-00-0

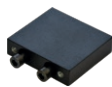

Bracket for opposite torch placement
DYS-0759-08-00-00-0

Standard shipping set:

- Tractor
- Plastic box
- Bracket
- 3, 4, 5 mm hex wrench
- Battery 4.0 Ah (2 pcs)
- Operator's manual

Optional accessories:



Cross-slide with bracket
ZSP-0759-07-00-00-0



Enlarged cross slide bracket
WSP-0759-12-01-00-0



Auxiliary magnet blocks
ZSP-0759-10-00-00-0



Cable anchor
PDT-0526-21-00-00-0



Battery Charger
LDW-0738-10-00-30-0 (EU)
LDW-0738-06-00-30-0 (AUS/NZ)
LDW-0738-04-00-30-0 (UK)

Torch position - left or right side

For continuous operation, the cross-slide with torch holder is positioned on the left side of the tractor. The torch can be mounted on the right side for short-term use of up to 10 minutes, ideal for completing the weld. No optional accessories are required to change the torch position side.



Cross-slide with torch holder on the left side: suitable for continuous operation



Cross-slide with bracket with torch holder and bracket are included in standard shipping set



Cross-slide with torch holder on the right side: suitable for operation up to 10 minutes

Dimensions:

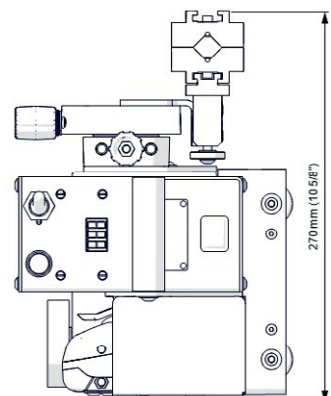
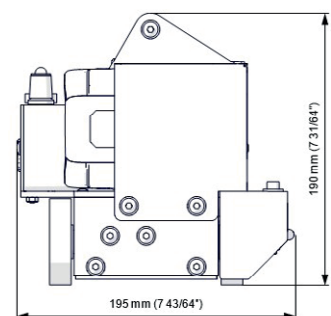

Optional configuration with two cross slides and two torch holders

If the customer finds it useful to have the tractor ready to hold a torch on either side, the optional cross slide is needed.



Torch to be hold on the left side



Optional cross-slide with bracket



Torch to be hold on the left or right side



GECKO

COMPACT WELDING TRACTOR

Gecko is a portable trackless welding tractor that features a 4-wheel drive system with magnetic traction and a control loop feedback mechanism that provides speed stabilization in all welding positions.

Constant, continuous, and repeatable travel speed enables weld bead geometry that is exact to the required specifications, thus reducing costly over welding and decreasing filler metal usage, substantially.

Users can select arc ignition times of up to 5 seconds at the start and end of tractor travel to create a preferred weld fill at both ends.

A wide range of accessories makes Gecko suitable for a variety of positions and applications.

A compact design tractor weighing 8 kg can be carried anywhere.

Applications:

- Trailer manufacturing
- Truck tanks
- Oil tanks
- Water storage tanks
- Transformers
- Shipyards
- Any application demanding a long, continuous fillet weld

42V AC version available

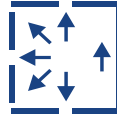

GECKO HS (High Speed)
with increased horizontal speed up to 220 cm/min (86.6 in/min) is suitable for both speed welding and plasma cutting

TECHNICAL SPECIFICATIONS	GECKO	GECKO HS
Voltage	1~ 115-230 V, 50-60 Hz 42 V, 50-60 Hz	1~ 115-230 V, 50-60 Hz 42 V, 50-60 Hz
Power	20 W	20 W
Welding position (according to EN ISO 6947 and AWS/ASME)	PA / 1F / 1G PB / 2F PC / 2G PD / 4F PE / 4G PG / 3F / 3G (contact dealer)	PA / 1F / 1G PB / 2F PC / 2G PD / 4F PE / 4G
Torch diameter	16-22 mm (0.63-0.87"); up to 35 mm (1.38") option	16-22 mm (0.63-0.87"); up to 35 mm (1.38") option
Minimum radius of curved workpiece surface	Outer 600 mm (23-5/8") Inner 800 mm (31-1/2")	Outer 600 mm (23-5/8") Inner 800 mm (31-1/2")
Minimum workpiece thickness	4 mm (0.16")	4 mm (0.16")
Ground clearance	4 mm (0.16")	4 mm (0.16")
Horizontal pulling force	150 N	150 N
Vertical pulling force	100 N	N/A
Cross slide adjustment range	0-35 mm (0-1.38") up down, left-right	0-35 mm (0-1.38") up down, left-right
Horizontal speed	0-110 cm/min (0-43.3 in/min)	5-220 cm/min (1.5-86.6 in/min)
Vertical speed	0-100 cm/min (0-39.4 in/min)	N/A
Weight	8 kg (18 lbs)	8 kg (18 lbs)
Welding settings storage	1 (last used)	1 (last used)
Product Code (115-230 V, 50-60 Hz, plug EU)	WOZ-0752-10-20-00-0	WOZ-0772-10-20-00-0
Product Code (115-230 V, 50-60 Hz, plug UK)	WOZ-0752-10-20-01-0	WOZ-0772-10-20-01-0
Product Code (42 V, 50-60 Hz)	WOZ-0777-10-04-00-0	WOZ-0778-10-04-00-0

- Continuous welding
- Dual torch welding
- Horizontal speed 0-110 cm/min (0-43.3 in/min)
- Vertical speed 0-100 cm/min (0-39.4 in/min)
- Dual Arc Ignition
- Min. path convex radius 600 mm (23.6")
- Min. path concave radius 800 mm (31.5")
- Weight 8 kg (18 lbs)

Versatility of Gecko welding tractor applications including out-of-position use

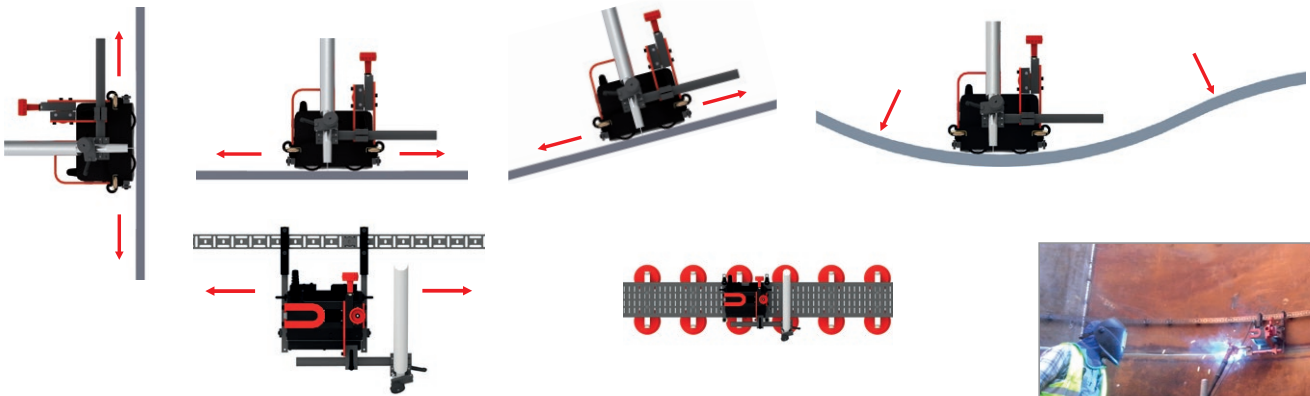

1. Drive unit with control panel
2. Adjustable guide arm
3. Quick clamp torch holder
4. Cross slide assembly
5. Main power switch (0/I)
6. Weld contact / Arc ignition socket
7. Lug for fall arrester

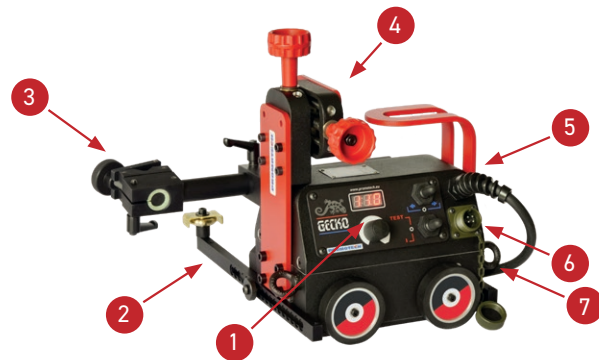

Standard accessories

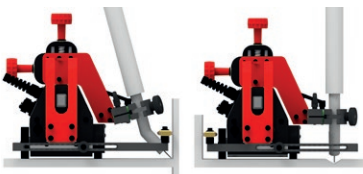

Primary features and benefits of Gecko welding tractor:

- The closed-loop speed control system stabilizes travel speed, enabling uniform heat input to produce consistently high-quality welds
- Multifunctional LED display to present travel speed, units and diagnostic messages
- 4-wheel drive magnetic traction permits out-of-position use
- Possibility of pre-setting the torch activation time before and after the tractor travel for better filling of the weld seam at both ends
- Convenient Power Supply 115-230 V, 50-60 Hz or 42 V, 50-60 Hz
- Gecko produces consistently high-quality welds and cuts in a fraction of the time required by manual operations
- Reduce wasted filler metal - eliminates over welding
- Compact, lightweight design with durable aluminum cast housing
- Positive magnetic traction permits out of position use
- Heat resistant silicone wheels
- Quick clamping Torch Holder mechanism for different types of MIG/MAG torches with diameters of 16-22 mm (5/8" - 7/8"); optionally up to 35 mm (1-3/8")
- Precise torch adjustment with screw drive cross slide
- Capable of carrying and controlling 2 torches
- Self-guiding roller arms eliminate the need for track
- Multi-surface guiding with user-friendly adjustment of tractor position
- Improves working environment - removes operator from heat and fumes
- Thermal cutting possible

Pre-setting torch activation time:

- Users can now select arc ignition times of up to 5 seconds at the start and end of the GECKO travel to create a preferred weld fill at both ends.

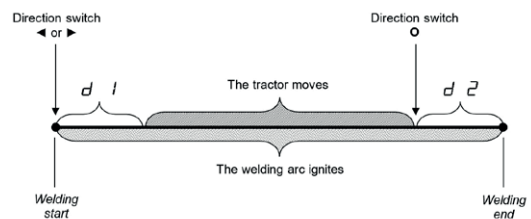

Parameter	Value	Description
$d1$	0-5 s [step: 0.5 s]	Tractor movement delay time. When the direction switch is set to ◀ or ▶: • $d1 = 0$ s - the arc ignites and the tractor starts immediately, • $d1 > 0$ s - the arc ignites and the tractor starts after the set time (see drawing above)
$d2$	0-5 s [step: 0.5 s]	Arc out delay time. When the direction switch is set to 0: • $d2 = 0$ s - the tractor stops and the arc goes out immediately, • $d2 > 0$ s - the tractor stops and the arc ignites for the set time (see drawing above)



GECKO BATTERY 2 | MOBILE WELDING TRACTOR

The GECKO Battery 2 is a battery-powered trackless welding tractor designed to produce continuous butt and fillet welds using MIG/MAG torches. CAS LiHD battery delivers enough power for handling even the toughest applications with no cables. 4-wheel drive system with magnetic traction and a feedback loop provide speed stabilization in various welding positions.

Constant, continuous and repeatable travel speed enables weld bead geometry that is exact to the required specifications, thus reducing costly over welding and substantially decreasing filler metal usage.

Users can select arc ignition times of up to 5 seconds at the start and end of tractor travel to create a preferred weld fill at both ends.

GECKO Battery 2 is ready to be configured with an external OSC-8 PRO pendulum oscillator, which can be powered from the built-in oscillator socket.



BOOST YOUR MOBILITY WITH BATTERY POWER!
No need for power cables

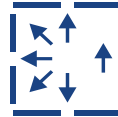

Control system of battery pack:

Detection and supervised parameters:

- too low and too high voltage
- too low and too high temperature
- failure of the temperature sensor
- internal battery failure

Benefits:

- over discharge protection
- extended battery life
- high level of safety for both tractor and operator

Applications:

- Trailer manufacturing
- Truck tanks
- Oil tanks
- Water storage tanks
- Transformers
- Shipyards
- Any application demanding a long, continuous fillet weld

TECHNICAL SPECIFICATIONS GECKO BATTERY 2		
Voltage	18 V DC, 4.0 Ah	
Power	20 W	
Welding position (according to EN ISO 6947 and AWS/ASME)	Horizontal	PA / 1F / 1G PB / 2F PC / 2G PD / 4F PE / 4G PF / 3G
	Vertical	PF / 3F (with OSC-8 PRO)
Minimum path curve radius	Outer	600 mm (23-5/8")
	Inner	800 mm (31-1/2")
Torch diameter	16-22 mm (5/8"-55/64") up to 35 mm (1.38") option	
Minimum workpiece thickness	4 mm (0.16")	
Ground clearance	4 mm (0.16")	
Horizontal pulling force	150 N	
Cross slide adjustment range	0-35 mm (0-1.38"), up-down, left-right	
Horizontal speed*	0-110 cm/min (0-43.3 in/min)	
Weight	8.4 kg (18.5 lbs)	
Welding settings storage	1 (last used)	
Product Code	WOZ-0805-10-00-00-0	

* With battery fully charged.

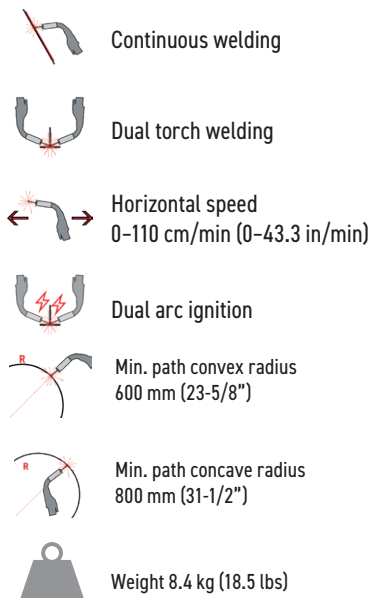

Versatility of applications including out-of-position use

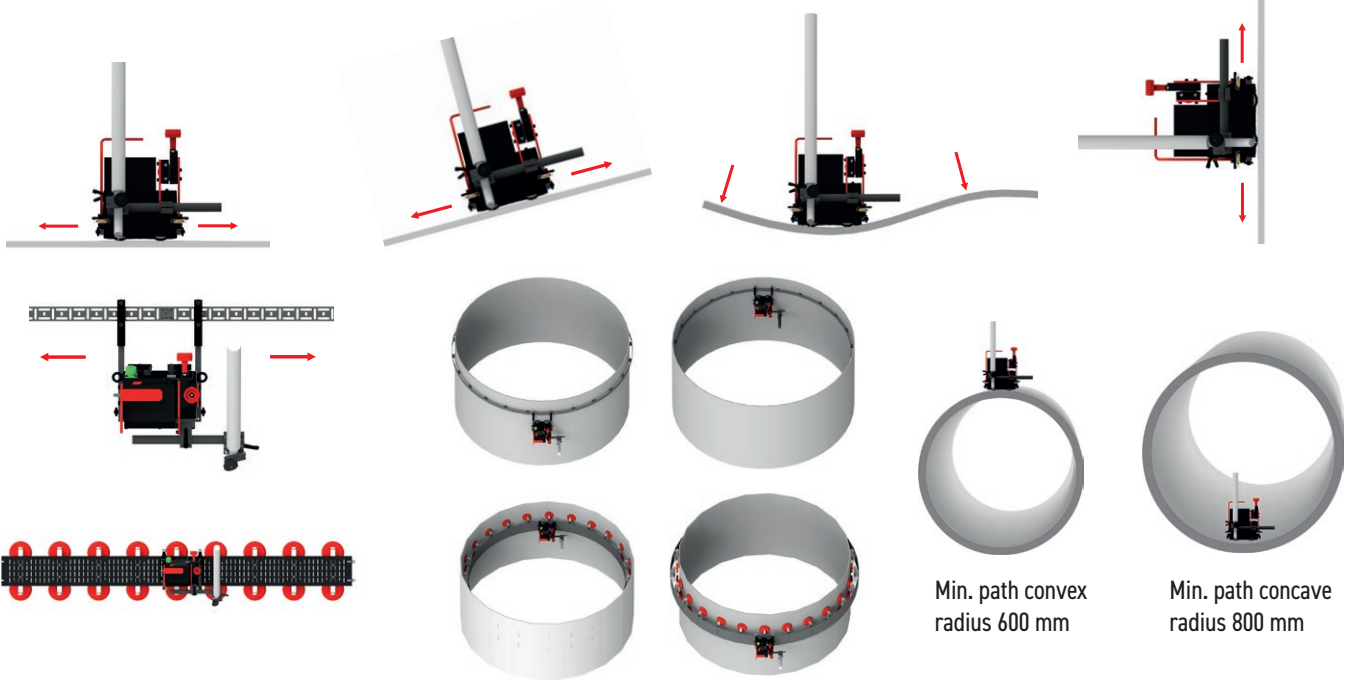

Min. path convex radius 600 mm

Min. path concave radius 800 mm

Features and benefits:

- Conveniently powered by an 18-volt DC battery – the same CAS battery as used in other cordless PROMOTECH machines
- LiHD battery ensures extended power availability even for the whole shift
- Intelligent battery management for long-lasting battery
- Digital speed control and stabilization for high quality welds
- Multifunctional LED display to present travel speed, units and diagnostic messages
- Compact, lightweight design with durable aluminum cast housing
- Optional accessories make Gecko Battery 2 fit for various applications with carbon steel, stainless steel and aluminum
- Possibility of pre-setting the torch activation time before and after the tractor travel for better filling of the weld seam at both ends
- Built-in oscillator socket for direct powering of external OSC-8 PRO pendulum oscillator
- Strong magnetic traction permits out of position use
- Heat resistant silicone wheels
- Quick clamping torch holder mechanism for different types of MIG/MAG torches with diameters of 16-22 mm (5/8"-7/8"); optionally up to 35 mm (1-3/8")
- Precise torch adjustment with screw drive cross slide
- Consistent heat input reduces distortion
- Reduced wasted filler metal - eliminates over welding
- Automatic arc on/off system initiates welding with travel, simultaneously
- Capable of carrying and controlling two torches
- Self-guiding roller arms eliminate the need for track
- Multi-surface guiding with user-friendly adjustment of tractor position
- Improves working environment - removes operator from heat and fumes
- Thermal cutting possible

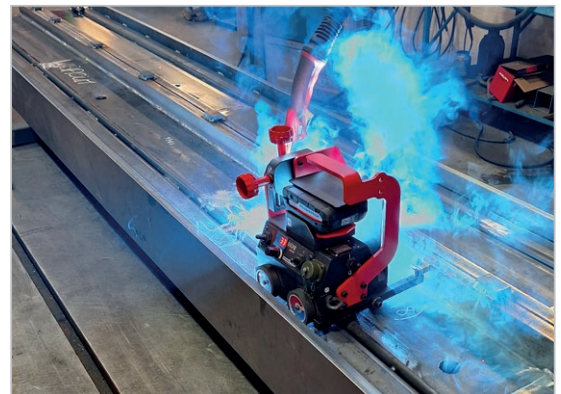

Pre-setting torch activation time:

- Users can now select arc ignition times of up to 5 seconds at the start and end of the Gecko Battery 2 travel to create a preferred weld fill at both ends.

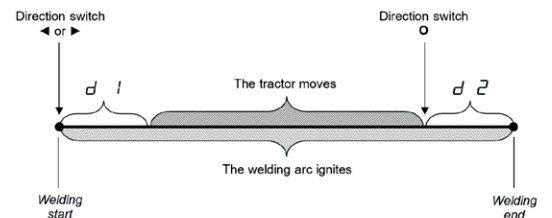

Standard accessories:



Battery 4.0 Ah (2 pcs included)
AKM-0738-10-00-01-0



Start-Stop arc ignition cable 6.5 m
KBL-0466-17-00-00-0



Standard guide arms 15 x 15 mm
(set of 2 pcs)
ZST-0752-17-00-00-1



Long rod torch holder with clamp 16-22 mm
UCW-0752-07-00-00-0

Parameter	Value	Description
$d1$	0-5 s [step: 0.5 s]	Tractor movement delay time. When the direction switch is set to ◀ or ▶ : • $d1 = 0$ s - the arc ignites and the tractor starts immediately, • $d1 > 0$ s - the arc ignites and the tractor starts after the set time (see drawing above)
$d2$	0-5 s [step: 0.5 s]	Arc out delay time. When the direction switch is set to 0: • $d2 = 0$ s - the tractor stops and the arc goes out immediately, • $d2 > 0$ s - the tractor stops and the arc ignites for the set time (see drawing above)



SCORPIO BATTERY

CORDLESS PROGRAMMABLE WELDING TRACTOR

The SCORPIO BATTERY is a battery-powered, programmable welding tractor designed for producing fillet and butt welds in both stitch and continuous welding modes. Its programming function allows you to set the desired welding path by specifying parameters such as weld length, skip length as well as crater filling at the beginning and the end of the welds.

The CAS LiHD (High Density Lithium Ion) battery provides sufficient power for handling even the toughest applications without the need for cables.

Travel speed control and stabilization enable precise matching of weld bead geometry to required specifications, reducing costly over-welding and significantly decreasing filler metal consumption.

The SCORPIO BATTERY can also produce weave welds with the use of an optional pendulum oscillator, which allows for precise control of weave width, weave speed, and left/right side dwell times.

Features and benefits:

- Simple and ergonomic programming of welding patterns and stitch welding parameters
- Multifunctional LED display presenting travel speed, units, welding settings, and diagnostic messages
- Closed-loop speed control system stabilizes travel speed, enabling uniform heat input for consistently high-quality welds
- Convenient 18 V DC battery supply (the same 4.0 Ah battery for MINI SPIDER BATTERY, Gecko Battery 2 and DRAGON BATTERY tractors)
- High Density Lithium Ion battery (LiHD) ensures maximum power availability for extended periods
- Intelligent battery management for long-lasting performance
- 4-wheel drive system with magnetic traction for stable movement of the tractor
- Compact, lightweight design with durable aluminum cast housing
- Optional pendulum oscillator for producing weave welds
- Auxiliary accessories make SCORPIO BATTERY suitable for various applications with carbon steel, stainless steel and aluminium
- Equipped with limit switches

Standard shipping set:

- Tractor
- Plastic box
- Battery 4.0 Ah (2 pcs included)
- Torch holder
- Arc ignition cable
- 4 mm hex wrench
- 3 mm hex wrench
- Operator's manual

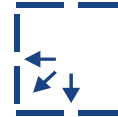

BOOST YOUR MOBILITY WITH BATTERY POWER!
No need for power cables

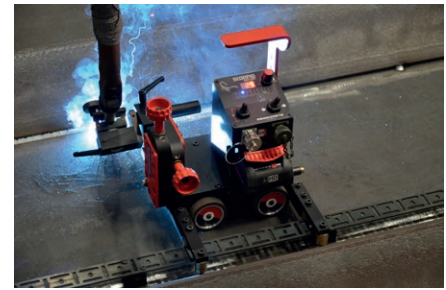

SCORPIO BATTERY - TECHNICAL SPECIFICATION		
Voltage		18 V DC, 4 Ah
Power		18 W
Welding position (according to EN ISO 6947 and AWS/ASME)		PA/1F/1G PB/2F PC/2G
Minimum path curve radius	Outer	1000 mm (39 3/8")
	Inner	1250 mm (49 7/32")
Torch type		MIG/MAG
Torch diameter		16-22 mm (5/8"-55/64") up to 35 mm (1.38") option
Minimum workpiece thickness		4 mm (5/32")
Ground clearance		4 mm (5/32")
Horizontal pulling force		150 N
Horizontal speed (with a fully charged battery)		5-130 cm/min (1-51 in/min)
Weight (without the battery)		7 kg (15.4 lbs)
Maximum torch reach		70 mm (2 3/4")
Product code		WOZ-0757-10-00-00



Continuous welding



Stitch welding



Angular oscillation (option)



Welding path programming



Dual torch welding



Dual Arc Ignition



Horizontal speed
5-130 cm/min
(2-51 in/min)



Min. path concave radius
1250 mm (49 7/32")



Min. path convex radius
1000 mm (39 3/8")

Programmable variables diagram

Simple and ergonomic programming of welding patterns and stitch welding by specifying parameters such as weld length, skip length and crater filling at the beginning and the end of the welds.

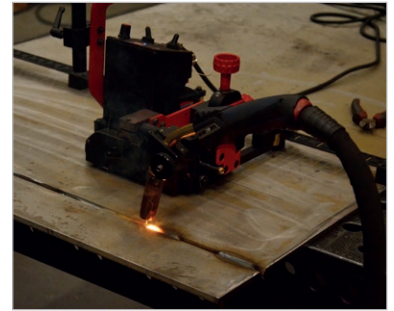
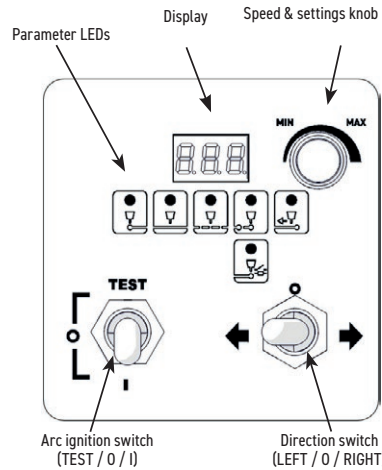

Standard accessories:



Battery 4.0 Ah (2 pcs included) AKM-0738-10-00-01-0



Start-Stop arc ignition cable 6.5 m KBL-0466-17-00-00-0



Standard guide arms 15 x 15 mm (set of 2 pcs) ZST-0752-17-00-00-1



Ultra-short rod torch holder with clamp 16-22 mm UCW-0757-09-00-00-0

The following oscillation parameters can be set and adjusted with both pendulum weave welders:

- oscillation width
- oscillation speed
- dwell time on both ends

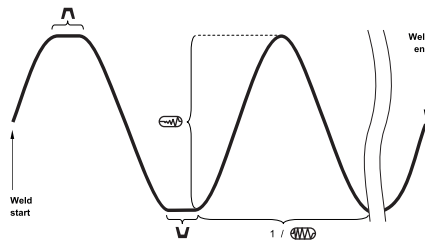

OSC-8 PRO support for SCORPIO Battery (including two M6x14 screws) WSP-0757-11-00-00-0

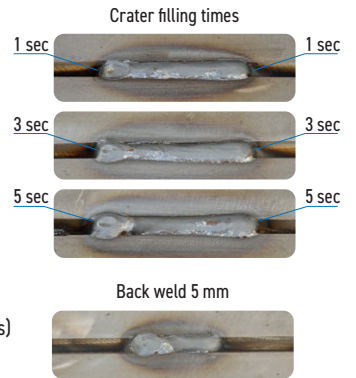

	Crater fill time Arc stabilization time	AST	0-5.0 sec [step: 0.1] Crater filling time at the beginning of the weld
	Weld length		0.5-99.9 cm [step: 0.1] 0.5-40" [step: 0.1]
	Skip length	- - -	0.5-99.9 cm [step: 0.1] 0.5-40" [step: 0.1]
	Crater fill	CF CFP	0-5.0 sec [step: 0.1] Crater filling time at the end of the weld
	Off (default)	OFF	Current curve set on Welding Source
	On	ON	Full current from Welding Source
	Reverse filling length	- b -	0-2 cm [step: 0.1] 0-1" [step: 0.1]
All LEDs on	Total length		1-999 cm [step: 1] 1-400" [step: 1] INF

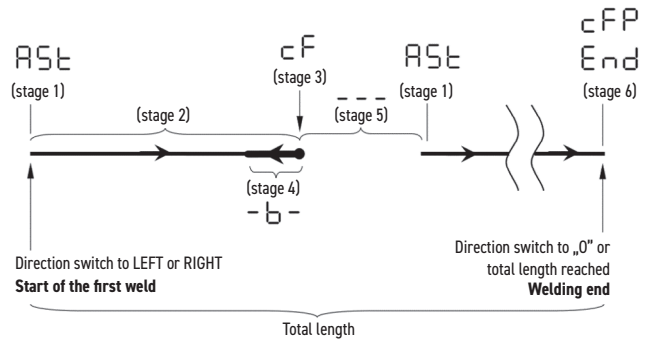

Stage 1	Arc stabilization and crater filling at the beginning of the weld
Stage 2	Tractor moves with the set speed and creates the weld of a defined length
Stage 3	Crater filling at the end of the weld
Stage 4	Back weld (Reverse filling length)
Stage 5	Tractor skips between welds. Next steps 1, 2, 3, 4 and 5 are repeated until total length is reached
Stage 6	Final crater filling (the end of welding procedure)

Joint accessories for Gecko, Gecko HS, Gecko Battery 2 and Scorpio Battery

Guide arms enable a proper welding tractor positioning.

- 7 different guide types are dedicated to various welding applications and positions
- include a number of fixing grooves for your convenience
- enable simpler, easier and more consistent adjustment of how guide arms stick out
- secure proper tilting of the tractor into a direction of its movement
- maintain a permanent contact with the workpiece
- allow either interval or continuous guide arms adjustment

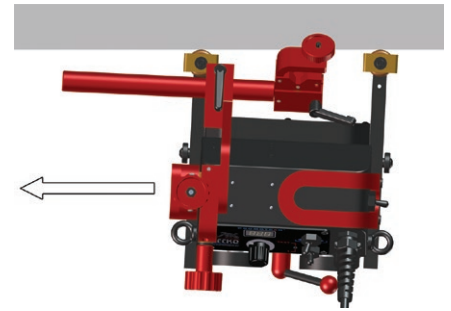

Each new guide arm has got a number of indented grooves only on one side. All types of guide arms are available in pairs of 2 pcs: right and left.

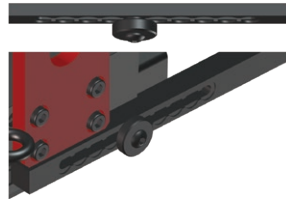

Interval adjustment of a degree how much the guide arms stick out

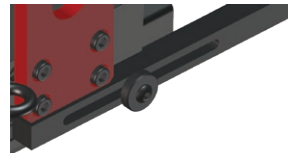

Continuous adjustment of a degree how much the guide arms stick out



Standard guide arms 15 x 15 mm (set of 2 pcs) ZST-0752-17-00-00-1

Optional accessories for multi-surface guiding and variety of applications



Low guide arms 15 x 15 mm (set of 2 pcs) PRW-0752-12-00-00-1



High guide arms 15 x 15 mm (set of 2 pcs) PRW-0752-13-00-00-1



Edge following guide arms 15 x 15 mm (set of 2 pcs) PRW-0466-41-00-00-1 (Except for Scorpio Battery)



Adjustable guide arms 15 x 15 mm (set of 2 pcs) PRW-0752-10-00-00-1

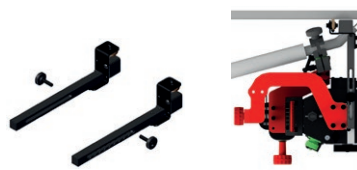

Magnet guide arms 15 x 15 mm (set of 2 pcs) PRW-0752-11-00-00-1



Following guide arms 15 x 15 mm for 36 mm wide flexible track (set of 2 pcs) PRW-0752-14-00-00-1



Optional accessories for variety of applications

	Torch clamp 16-22 mm ZRZ-0752-07-01-00-0		Torch clip 16-22 mm ZCS-0476-06-01-00-0		Torch clamp 22-35 mm ZRZ-0466-19-00-00-0		Torch extension arm for GECKO family and LIZARD PRD-0466-43-00-00-0
	Short Rod Clamp WLK-0476-20-01-00-0		Short rod torch holder with clip 16-22 mm UCW-0476-27-00-00-0		Long Rod Clamp WLK-0466-04-10-00-0		Torch extension arm for SCORPIO Battery PRD-0757-10-00-00-0
	Short rod torch holder with clamp 16-22 mm UCW-0754-07-00-00-0		Long rod torch holder with clip 16-22 mm UCW-0466-22-00-00-0		Long rod torch holder with clamp 16-22 mm UCW-0752-07-00-00-0		Torch Holder Lower Rod Clamp Assembly UCW-0476-06-00-00-0
	Battery Charger LDW-0738-10-00-30-0 (EU) LDW-0738-04-00-30-0 (UK)		Fall arrester device URZ-000001		Oscillator OSC-8 PRO OSC-0799-10-00-00-0		Cable anchor (Gecko) PDT-0466-55-00-00-0
							Cable anchor (Gecko Battery 2, Scorpio Battery) PDT-0776-04-00-00-0
	Dual Torch Mount PDT-0466-40-00-00-0		Oscillator support for GECKO and GECKO Battery 2 (incl. two M6x14 screws) KTW-0805-99-01-00-0		Oscillator support for SCORPIO Battery (including two M6x14 screws) WSP-0757-11-00-00-0		Extended cross-slide 0-76 mm (0-3") either up-down or left-right ZSP-0466-46-00-00-1
			Stainless steel drive wheel for GECKO family and SCORPIO Battery KOL-0466-72-00-00-0				
	Magnet blocks (front & back) clamping force 55 N BLO-0466-45-01-00-0		Magnet blocks (front) clamping force 80 N BLO-0752-22-00-00-0		Magnet blocks (back) clamping force 80 N BLO-0466-48-01-00-0		
	Guide arm screw short 30 mm SRB-0466-10-00-00-0		Display cover for GECKO and GECKO HS OSL-0466-29-00-00-0		Display cover for GECKO Battery 2 OSL-0526-22-00-00-0		

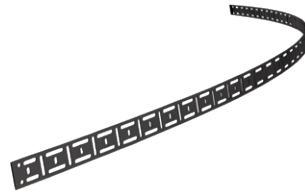
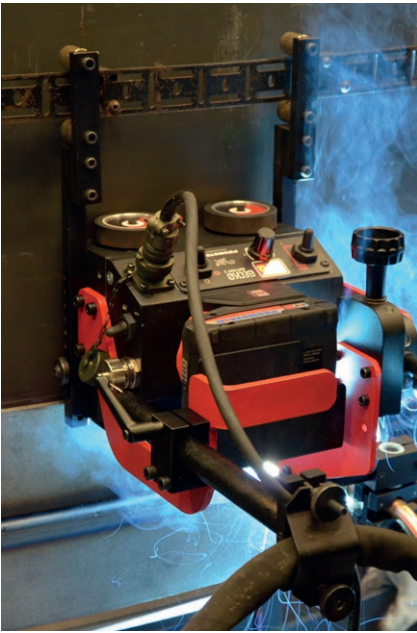

36 mm wide flexible track length 185cm (6ft) 1pc
Minimum curvature radius of 1.0 m (3.3 ft)
PRW-0466-50-01-01-0



Magnetic block for 36 mm wide flexible track
BLO-0466-68-00-00-0



Guide adjustment tool for 36 mm wide flexible track
UST-0466-53-00-00-0

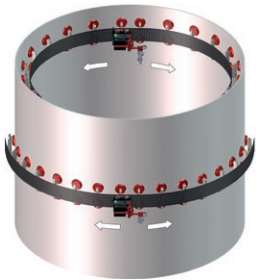
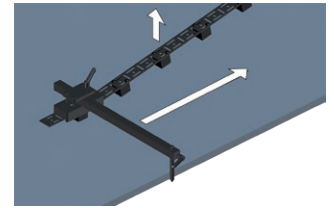

Vacuum units in use on stainless steel or aluminum tanks

Depending on sort of fixing units in use with flexible trackway, Gecko, Gecko Battery 2 welding tractors are suitable for applications with carbon steel, stainless steel and aluminum.

160 mm wide flexible track length 1.88 m (6.1 ft).
Minimum curvature radius of 1.25 m (4.1 ft)
PRW-0466-71-00-00-0

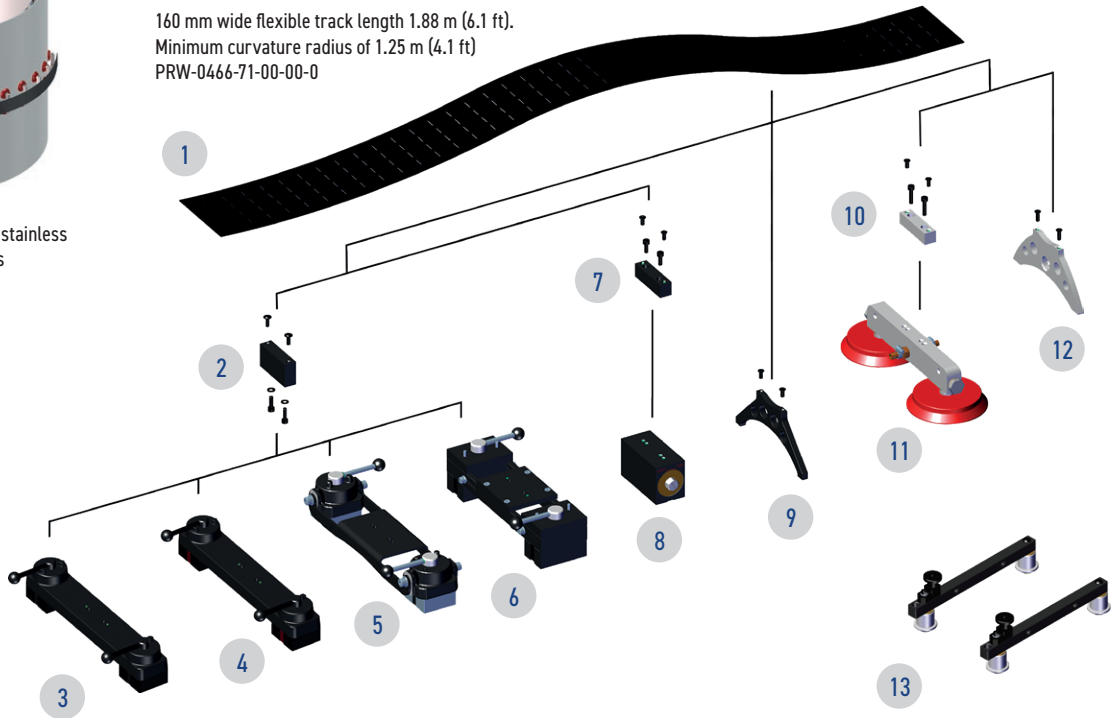

Ref.	Product code	Description
1	PRW-0466-71-00-00-0	160 mm wide flexible track length 1.88 m (6.1 ft), minimum curvature radius of 1.25 m (4.1 ft)
2	DYS-0466-71-05-00-0	Bracket for magnetic units for 160 mm wide flexible track
3	ZSP-0475-92-00-00-0	Magnetic unit
4	ZSP-0475-93-00-00-0	Heat-resistant magnetic unit
5	ZSP-0475-85-00-00-0	Pivoting magnetic unit
6	ZSP-0523-19-00-00-0	Spacing-adjustable magnetic unit
7	DYS-0466-71-07-00-0	Bracket for narrow magnetic unit for 160 mm wide flexible track
8	PDS-0582-10-00-02-0	Narrow magnetic unit with hexagon
9	WSP-0466-71-06-00-0	Steel support for 160 mm wide flexible track
10	DYS-0466-71-04-00-0	Bracket for vacuum modular unit for 160 mm wide flexible track
11	MST-0541-10-02-00-0	Vacuum modular unit
12	WSP-0466-71-03-00-0	Aluminium support for 160 mm wide flexible track
13	ZST-0466-69-00-00-0	Following guide arms for 160 mm wide flexible track (set of 2 pcs)

OSC-8 PRO | PENDULUM OSCILLATOR WITH LED DISPLAY



The OSC-8 PRO is a new generation pendulum oscillator with a built-in LED display and user-friendly pre-setting and control of four welding parameters: oscillation width, oscillation speed, right and left dwell times.

This is an ideal weave welding solution for many applications including: pipes, tubes, vessels, flanges, fittings, and much more.

Portable OSC-8 PRO pendulum oscillator can be combined with both track-mounted and trackless welding carriages, welding positioners, turning rolls, an existing welding system, such as a column and boom, or use it independently with the rugged freestanding supports.

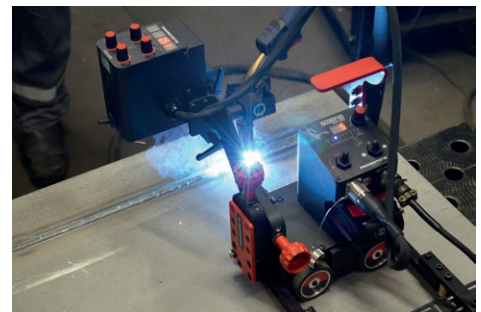

Features & Benefits:

- Lightweight and compact design
- Four adjustable parameters: oscillation width, oscillation speed, oscillation dwell time on ends
- Triangle and trapezoid weld paths
- Ergonomic control panel with four knobs
- Digital LED display enables precise setting and reading of oscillation parameters; it also indicates the current status of the OSC-8 PRO and provides safety and diagnostic information
- Two control modes: manual and external start
- Can operate as a stand-alone unit or be part of more advanced welding systems configured with welding tractors, columns and booms, positioners, gantry systems, etc.

OSC-8 PRO TECHNICAL SPECIFICATION

Voltage	14–24 V DC
Power	50 W
Torch type	MIG/MAG
Torch diameter	16–22 mm (5/8"–55/64")
Oscillation type	Angular
Oscillation width at r=150 mm (5 29/32")	1–30 mm; 3/64"–1 3/16" (3–99%)
Oscillation speed at oscillation width of 10 mm (3/8") and zero dwell time on ends	12–300 cycles/min
Dwell time on ends	0–5 s
Maximum torque	8 N·m
Protection level	IP 20
Protection class	I
Required ambient temperature	0–50°C (32–122°F)
Weight	2.1 kg (4.6 lbs)
Product code:	OSC-0799-10-00-00

OSC-8 PRO configurations at glance:

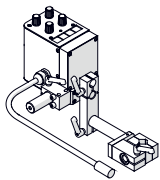

The OSC-8 PRO can be used in conjunction with a range of external equipment to create more advanced welding systems with a variety of power supplies, available operating modes and achievable weld paths (see table below).

	GECKO RAIL BULL RAIL TUG PRO-WP 150 PRO-WP 300 PRO-WP 300P PRO-WP 750P Torch stands	GECKO Battery 2 RAIL TITAN	SCORPIO Battery	RAIL TITAN 2 WA Compact SWSO
---	--	-------------------------------	-----------------	------------------------------------

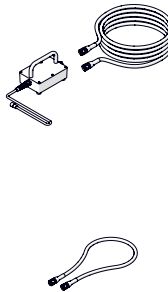
Power supply method

	External Power Supply ZSL-0720-03-00-05-0 (230V, EU) ZSL-0720-03-00-04-0 (230 V, D) ZSL-0720-03-00-01-0 (115 V, US) PWD-0720-04-00-00-0 Cable connecting adapter 1 m for OSC-8 PRO	Directly from oscillation socket of the machine	Directly from oscillation socket of the SCORPIO Battery	Directly from oscillation socket of the machine
--	---	--	---	--

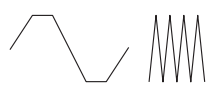

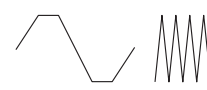

MANUAL operation mode

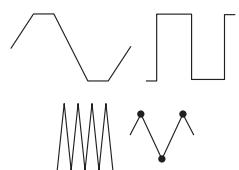
Oscillator settings:	MANUAL	MANUAL	MANUAL	MANUAL
Communication with the machine:	NO	NO	NO	NO
Weld paths:	TRAPEZOID and TRIANGLE 	TRAPEZOID and TRIANGLE 	TRAPEZOID and TRIANGLE 	TRAPEZOID and TRIANGLE 

EXTERNAL operation mode

Oscillator settings:	N/A	N/A	MANUAL	From remote control pendant of the machine
Communication with the machine:	N/A	N/A	YES (start/stop of both tractor & oscillator)	YES
Weld paths:	N/A	N/A	TRIANGLE and TRIANGLE with dwell times at both ends 	TRAPEZOID, SQUARE, TRIANGLE and TRIANGLE with dwell times at both ends 

Oscillation parameters:

Parameter	Value	Description
	3-99%	Oscillation width
	0-99% (where 0%=5s, 99%=0.2s) 0.2-5 s	Oscillation speed
	0-5 s [step: 0.1]	Oscillation dwell time in right position
	0-5 s [step: 0.1]	Oscillation dwell time in left position

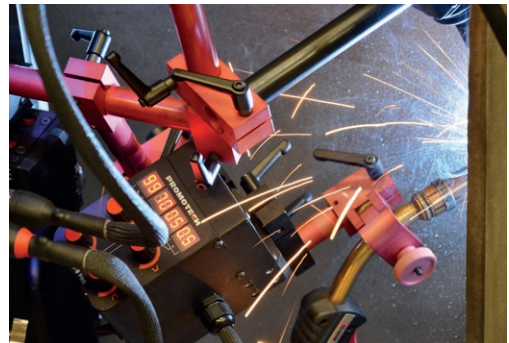
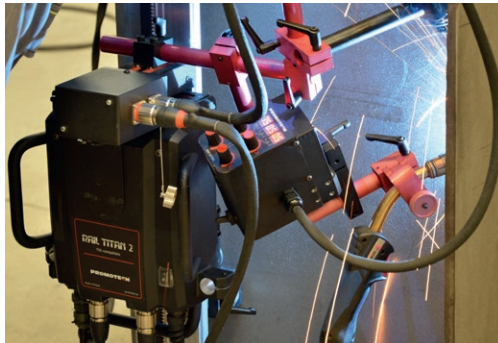
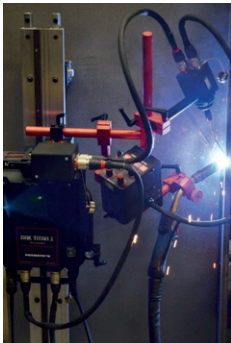
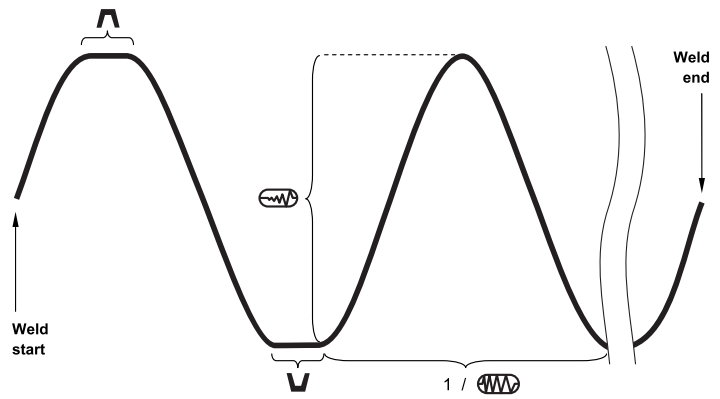

Standard shipping set:

- Oscillator
- 5 mm hex wrench
- Arm
- Low rod torch holder with clip
- Clamping block
- M6x40 screw 2 pcs
- 80 mm (3 5/32") rod
- Operator's Manual

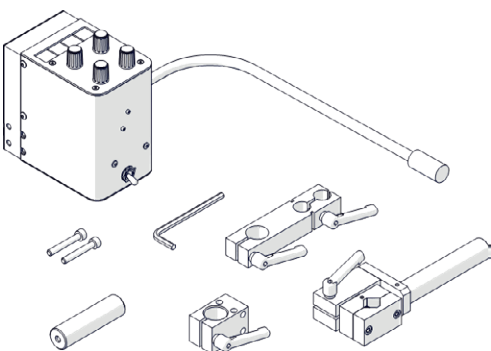

Optional Power Supply:

- Product codes:
- ZSL-0720-03-00-05-0 (230V)
 - ZSL-0720-03-00-04-0 (230 V, India type D)
 - ZSL-0720-03-00-03-0 (230 V, UK type G)
 - ZSL-0720-03-00-02-0 (230 V, Australia)
 - ZSL-0720-03-00-01-0 (115 V)

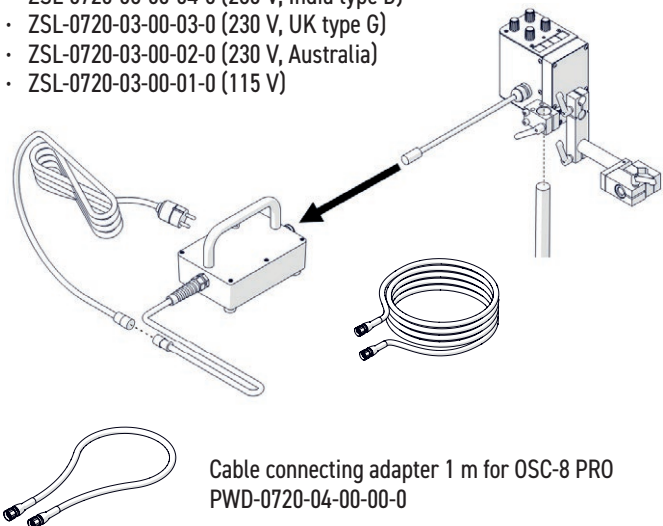



LIZARD | PROGRAMMABLE WELDING TRACTOR

Lizard is a portable, programmable, trackless welding tractor designed to produce consistently high-quality welds.

It can be programmed in continuous or stitch welding modes.

Welder-friendly two-function buttons enable storage and reproduction of up to 40 different welding programs for various joint configurations and multi-pass, multi-layer welds.

Constant, continuous, and repeatable travel speed enables weld bead geometry that is exact to the required specifications, thus reducing costly over welding and decreasing filler metal usage, substantially.

Lizard is capable of producing weave welds by means of an optional pendulum oscillator. The oscillator allows for precise control of weave speed, and left/right side wall dwell and is particularly useful for vertical welding.

Applications:

- Trailer manufacturing
- Truck tanks
- Oil tanks
- Water storage tanks
- Transformers
- Shipyards
- Any application demanding stitch or a long, continuous fillet weld

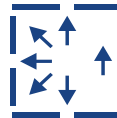

A very important optional feature of LIZARD is oscillation attachment to produce weave welds.

The unit can identify its connection automatically and configure suitable operating modes.

Torch oscillator increases significantly functionality of Lizard welding tractor by allowing it to operate in most out-of-position welding jobs.

TECHNICAL SPECIFICATIONS LIZARD	
Voltage	1- 115-230 V, 50-60 Hz 42 V, 50-60 Hz
Power	25 W
Welding position (according to EN ISO 6947 and AWS/ASME)	PA / 1F / 1G PB / 2F PC / 2G PD / 4F PE / 4G PF / 3F / 3G with optional oscillator PG / 3F / 3G (with optional oscillator)
Programmable variables	tractor speed, weld length, skip, crater fill, backweld, total length
Welding settings storage	up to 40
Menu language	English, French, German, Polish, Portuguese, Russian, Spanish, Turkish
Torch diameter	16-22 mm (0.63-0.87"); up to 35mm (1.38") option
Minimum radius of curved workpiece surface	1500 mm (5 ft)
Minimum workpiece thickness	5 mm (0.2")
Ground clearance	5 mm (0.2")
Horizontal pulling force	220 N
Vertical pulling force	150 N
Cross slide adjustment range	0-35 mm (0-1.38") up-down, left-right
Horizontal speed	0-130 cm/min (0-51 3/16 in/min)
Vertical speed	0-120 cm/min (0-47 1/4 in/min)
Limit switch	at both sides
Weight	14 kg (31 lbs)
Product Code (115-230 V, 50-60 Hz, plug EU)	WOZ-0754-10-20-02-0
Product Code (115-230 V, 50-60 Hz, plug UK)	WOZ-0754-10-10-03-0
Product Code (42 V, 50-60 Hz)	WOZ-0784-10-42-01-0



Programming device up to 40 welding programs



Dual Arc Ignition



Min. path convex radius
1500 mm (5 ft)



Angular oscillation



Dual torch welding



Min. path concave radius
1500 mm (5 ft)



Continuous welding



Horizontal speed
0-130 cm/min (0-51 3/16 in/min)



Vertical speed
0-120 cm/min (0-47 1/4 in/min)



Stitch welding



Weight 14 kg (31 lbs)

Versatility of applications including out-of-position use

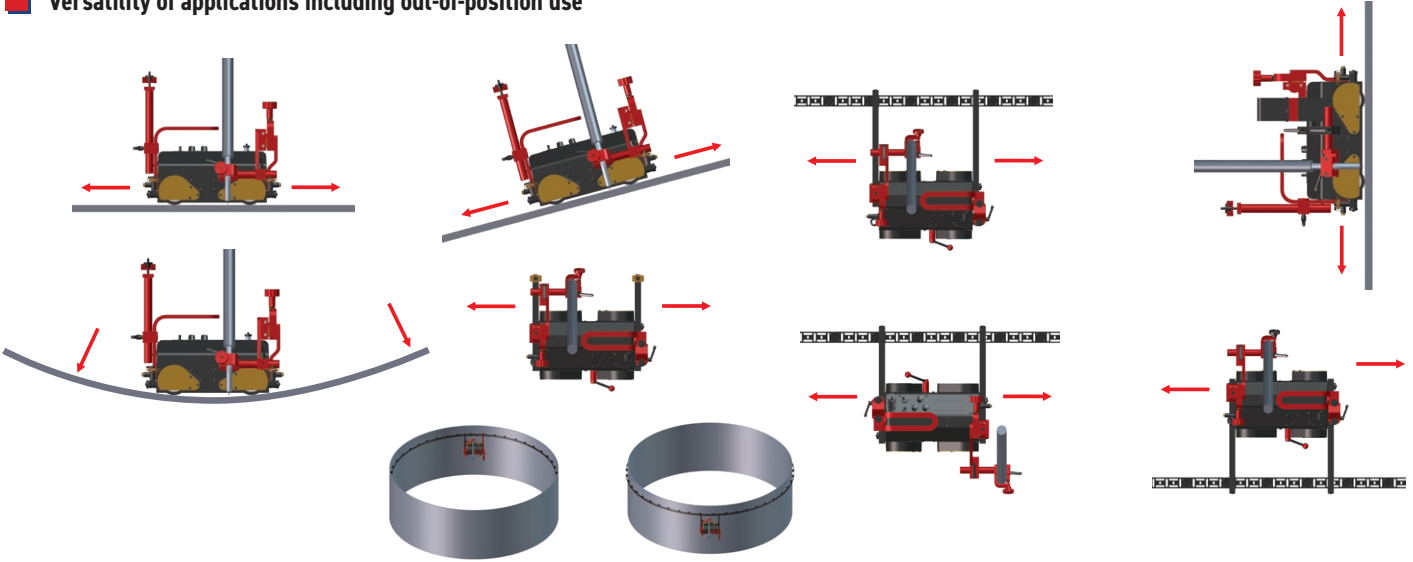

Primary features and benefits:

- Up to 40 complete programs may be stored in non-volatile memory to repeat optimum weld procedures
- Multifunctional LCD and 2-function buttons for programming selected welding patterns and parameters such as weld length, the distance between welds, reverse fill, crater fill time, and others
- The closed-loop speed control system stabilizes travel speed, enabling uniform heat input to produce consistently high-quality welds
- Lizard travels at full speed between stitches, which saves valuable welding time.
- The optional torch oscillator produces weave welds
- 4-wheel drive magnetic traction permits out-of-position use
- Compact, lightweight design with a durable aluminum cast housing
- Convenient Power Supply 115-230 V, 50-60 Hz or 42 V, 50-60 Hz
- Positive magnetic traction permits out of position use
- Magnet on/off lever permits easy set up and adjustment on work piece
- Heat resistant silicone wheels
- Quick clamping Torch Holder mechanism for different types of MIG/MAG torches with diameters of 16-22 mm (5/8" - 7/8"); optionally up to 35 mm (1-3/8")
- Precise torch adjustment with screw drive cross slide
- Consistent heat input reduces distortion
- Reduced wasted filler metal - eliminates over welding
- Automatic arc on/off system initiates welding and travel, simultaneously
- Capable of carrying and controlling 2 torches (without oscillation)
- Self-guiding roller arms eliminate the need for track
- Multi-surface guiding

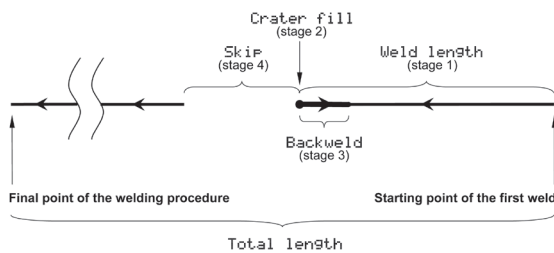
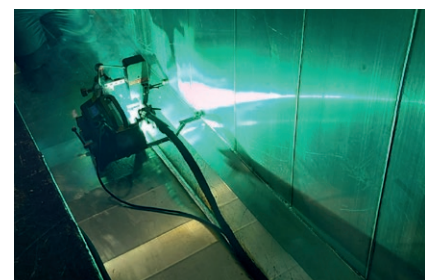

Programmable variables diagram

1. Operator's panel with control knobs and switches
2. Limit switch
3. Adjustable guide arm
4. Quick clamp torch holder
5. Cross slide assembly
6. Cable anchor
7. Main Power Switch (0/I)
8. Weld contact / Arc ignition socket
9. Magnetic adhesion release lever



Standard accessories

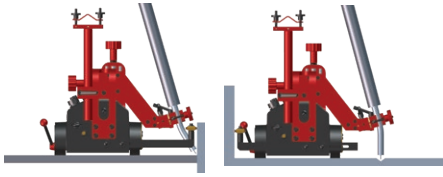

Standard guide arms
20 x 20 mm (set of 2 pcs)
PRW-0476-56-00-00-0



Start-Stop arc ignition
cable 6.5 m
KBL-0466-17-00-00-0



Short rod torch holder
with clamp 16-22 mm
UCW-0754-07-00-00-0



Cable anchor
PDT-0754-12-00-00-0

Optional accessories



Torch clamp 16-22 mm
ZRZ-0752-07-01-00-0



Torch clip 16-22 mm
ZCS-0476-06-01-00-0



Torch clamp 22-35 mm
ZRZ-0466-19-00-00-0



Short Rod Clamp
WLK-0476-20-01-00-0



Short rod torch holder
with clip 16-22 mm
UCW-0476-27-00-00-0



Fall arrester device
URZ-000001



Long rod torch holder
with clamp 16-22 mm
UCW-0752-07-00-00-0



Long rod torch holder
with clip 16-22 mm
UCW-0466-22-00-00-0



Long Rod Clamp
WLK-0466-04-10-00-0



Torch extension arm for
GECKO family and LIZARD
PRD-0466-43-00-00-0



Extended cross-slide
0-76 mm (0-3") either
up-down or left-right
ZSP-0466-46-00-00-1



Dual Torch Mount
PDT-0466-40-00-00-0

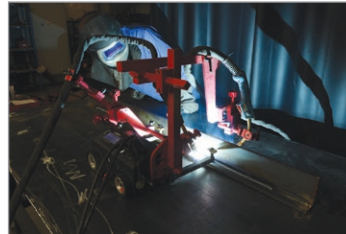
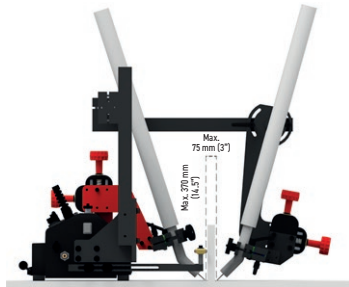

Optional accessories for multi-surface guiding and variety of applications



Low guide arms 20 x 20 mm (set of 2 pcs)
PRW-0476-54-00-00-1



High guide arms 20 x 20 mm (set of 2 pcs)
PRW-0476-55-00-00-1

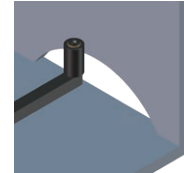
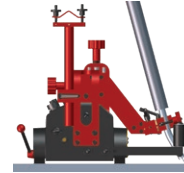

Edge following guide arms 20 x 20 mm (set of 2 pcs)
PRW-0476-21-00-00-1

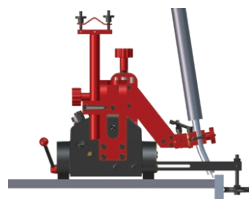

Adjustable guide arms 20 x 20 mm (set of 2 pcs)
PRW-0476-22-00-00-1

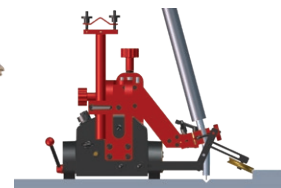



Following guide arms
20 x 20 mm for 36 mm wide
flexible track (set of 2 pcs)
PRW-0476-50-01-00-1

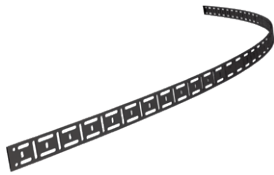

36 mm wide flexible track
185cm (6ft) 1 pc
PRW-0466-50-01-01-0



Magnetic block for 36 mm
wide flexible track
box of 10 pcs
BLO-0466-68-00-00-0

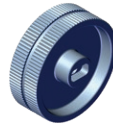

Stainless steel drive
wheel for LIZARD
KOL-0476-57-00-00-0



Guide adjustment tool to position 36 mm wide
flexible track parallel to the edge
UST-0466-53-00-00-0

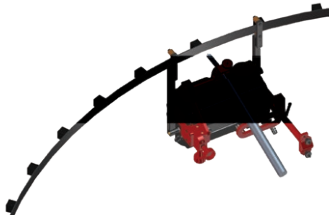
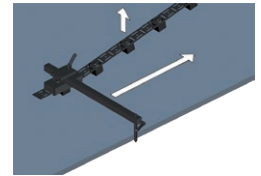

Magnet guide arms 20 x 20 mm
(set of 2 pcs)
PRW-0476-52-00-00-1



Guide arm screw
long 40 mm
SRB-0476-08-00-00-0



Display cover
for LIZARD
OSL-0476-23-00-00-0

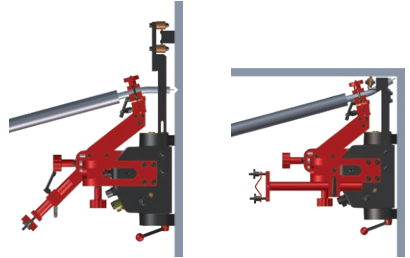

Optional Pendulum Oscillator

The oscillator features precise control of weave width, weave speed and dwell times.



Oscillator
ZSP-0477-10-00-00-0



Torch Holder Lower Rod Clamp Assembly
UCW-0476-06-00-00-0



Oscillator settings diagram

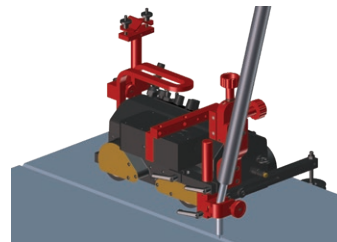
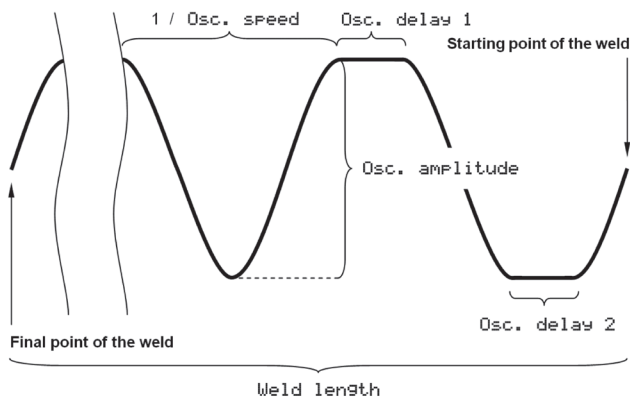

Oscillation type	pendulum (0°-11°)
Oscillation amplitude	1-30mm (1-100%) at r=150 mm (5.9")
Oscillation speed at oscillation amplitude of 10 mm (25/64") and zero dwell time on ends	7-164 cycles/min (1-100%)
Oscillation delay time	0-5 s (at external points)
Power	12 W
Weight	2.6 kg (5.7 lbs)



Fillet Welding with oscillator





RAIL BULL | WELDING & CUTTING RAIL TRACTOR

RAIL BULL is a digitally controlled welding tractor with an integrated linear oscillator that produces straight and trapezoid weld paths.

The tractor can move along rigid or semi-flexible tracks and is suitable for variety of circumferential and irregular surface applications down to min. radius of 5000 mm.

The tracks can be clamped to ferrous materials with magnetic units and to non-ferrous materials by means of a vacuum track system incl. vacuum pump and vacuum units.

Featuring a rack and pinion drive system with electronic speed control, RAIL BULL can produce consistent, high-quality welds in flat, vertical, or horizontal positions.

42V AC version available

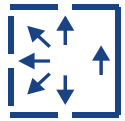

Features and benefits:

- Closed loop position control system based on an electric motor with an encoder ensures increased accuracy of speed and positioning
- Integrated linear oscillator for weave welding and overlay
- Multifunctional LCD shows process parameters and warnings
- Compact, lightweight design with a durable aluminum cast housing
- Convenient power supply 115-230 V, 50-60 Hz or 42 V, 50-60 Hz
- Rail Bull produces consistently high-quality welds and cuts in a fraction of the time required by manual operations
- Quick clamping torch holder mechanism for different types of MIG/MAG torches with diameters of 16-22 mm (0.63-0.87"); up to 35 mm (1.38") option
- Precise torch adjustment with screw drive cross slide
- Ready to work in both vertical and horizontal positions
- Consistent heat input reduces distortion
- Reduce wasted filler metal - eliminates over welding
- Automatic arc on/off initiates welding and travel, simultaneously
- Improves working environment - removes operator from heat and fumes
- Rack and pinion drive



RAIL BULL TECHNICAL SPECIFICATION		
Voltage	1- 115-230 V, 50-60 Hz 42 V, 50-60 Hz	
Power	100 W	
Welding position (according to EN ISO 6947 and AWS/ASME)	Horizontal	PA/1F/1G PB/2F PC/2G PD/4F PE/4G PF/3G
	Vertical	PG/3F (contact your dealer) PG/3G
Minimum curve radius of a semi flex track	5 m (16 ft)	
Torch type	MIG/MAG	
Torch diameter	16-22 mm (5/8"-55/64") up to 35 mm (1.38") option	
Minimum workpiece thickness for magnetic clamping	5 mm (13/64")	
Horizontal pulling force	350 N	
Vertical pulling force	150 N	
Cross slide adjustment range	0-35 mm (0-1 3/8", up-down, left-right)	
Horizontal speed	0-120 cm/min (0-47 1/4 in/min)	
Vertical speed	0-110 cm/min (0-43 5/16 in/min)	
Oscillation type	Linear	
Oscillation path	Trapezoid, straight line	
Oscillation width	0-50 mm (0-1 31/32")	
Oscillation speed	0-1500 mm/min (0-59 1/16 in/min)	
Oscillation dwell time at center and on ends	0-5 s	
Maximum oscillator pulling force	100 N	
Weight	16,5 kg (36.3 lbs)	
Product Code (115-230 V, 50-60 Hz, plug EU)	WOZ-0760-10-20-00-0	
Product Code (115-230 V, 50-60 Hz, plug G)	WOZ-0760-10-20-01-0	
Product Code (42 V, 50-60 Hz)	WOZ-0624-10-04-00-0	

- Continuous welding
- Horizontal speed 0-120 cm/min
- Vertical speed 0-110 cm/min
- Linear oscillation with trapezoid and straight line paths
- Min. path convex radius 5000 mm
- Min. path concave radius 5000 mm

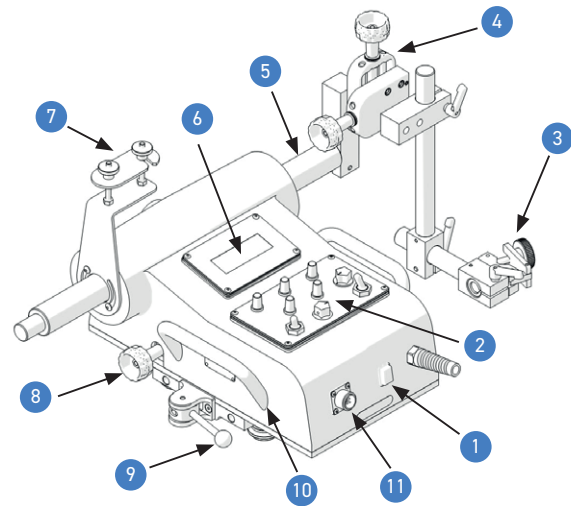
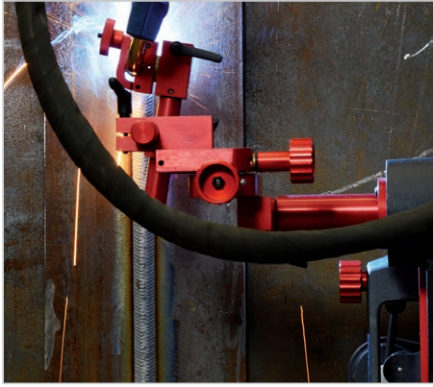

- | | |
|----------------------------|-------------------------|
| 1. Power switch | 7. Cable anchor |
| 2. Control panel | 8. Drive clutch knob |
| 3. Torch holder with clamp | 9. Mounting lever |
| 4. Cross slide assembly | 10. Carrying handle |
| 5. Oscillator arm | 11. Arc ignition socket |
| 6. Display | |

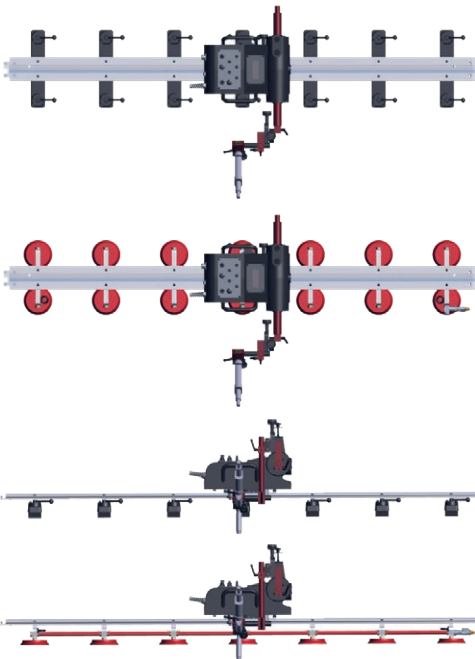
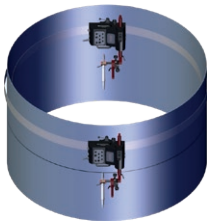

Weld paths:



- I. Trapezoid The tractor travels continuously even during dwell mode. Weld path is determined by weave speed and dwell time at center and on sides of the weld path.
- II. Straight The tractor travels continuously while oscillation is switched-off.

Standard shipping set:

- Carton box
- Cross slide assembly
- Short rod torch holder with clamp
- 6.5 m (21 ft) arc ignition cable
- 3 mm hex wrench
- 4 mm hex wrench
- Operator's Manual

Standard accessories:



Start-Stop arc ignition cable 6.5 m
KBL-0466-17-00-00-0



Short rod torch holder
with clamp 16-22 mm
UCW-0754-07-00-00-0



Cable Anchor
WSP-0760-06-00-00-0

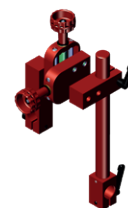

Cross slide assembly
PRW-0482-11-00-00-0



RAIL TUG | TRACK WELDING AND CUTTING TRACTOR

The Rail Tug is a digitally controlled tractor designed for the mechanization of welding and thermal cutting processes. Featuring a rack and pinion drive system with electronic speed control, Rail Tug creates weld bead geometry which is exact to your specifications, reducing costly over welding and decreasing filler metal usage.

It can be used with semi-flexible tracks for plate and tank work with a minimum radius of 5 m (16 ft) or adapted to bent ring rail for pipe and tube applications.

Hi-Flex tracks are suitable for variety of circumferential and irregular surface applications down to minimum radius of 750 mm (30")

Standard ring tracks are available for tube diameters from 200 mm (8") up to 3000 mm (10 ft).

Using a vacuum system allows the tracks to be clamped to non-ferrous surfaces (stainless steel, aluminum etc.)

The Rail Tug economically meets a broad array of welding and cutting applications on flat or curved plate, tube and pipe.

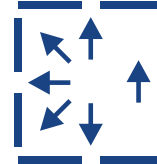
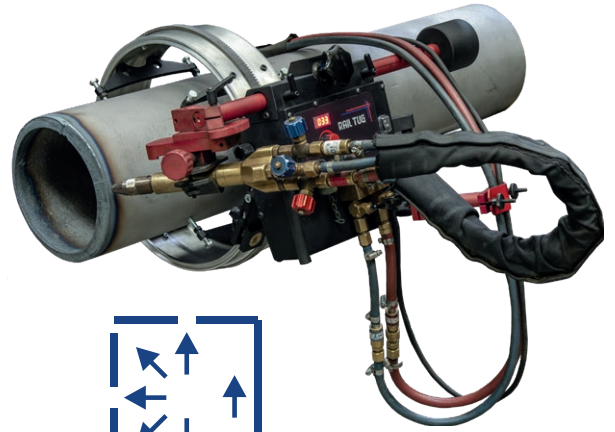

Features and benefits:

- Compact, lightweight design
- Closed-loop speed control system based on electric motor with encoder – ensures increased accuracy of speed
- Rack and pinion drive
- Consistent heat input reduces distortion
- Reduces wasted filler metal – eliminates over welding
- Digital LED display for presetting of travel speed
- Automatic arc on/off initiates welding and travel simultaneously
- Oxy-fuel and plasma cutting possible with optional accessories
- Suitable for variety of circumferential and irregular surface applications down to minimum radius of 100 mm (4")
 - Ring tracks on diameters from 200 mm (8") OD up to 3 m OD
 - Hi-Flex tracks on diameters from 1500 mm (59") OD upwards
 - Semi-flexible tracks can be bended to minimum radius of 5 m without permanent deformation
- Quick-clamping torch holder mechanism for different types of torches with diameters of 16–22 mm (0.63–0.87"); up to 35 mm (1.38") option
- Precise torch adjustment with screw drive cross slide
- Convenient external 85-250 V power supply
- Improves working environment – removes operator from heat and fumes

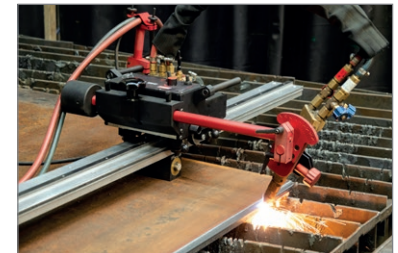
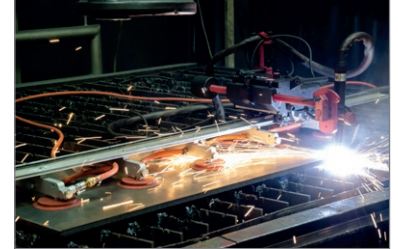

RAIL TUG TECHNICAL SPECIFICATION	
Voltage	1~ 115-230 V, 50-60 Hz
Power	66 W
Welding position (according to EN ISO 6947 and AWS/ASME)	PA / 1F / 1G PB / 2F PC / 2G PD / 4F PE / 4G PG / 3F (contact your dealer)
Fixing on pipes and round workpieces	Ring tracks from 200 mm (8") OD up to 3 m (10ft) OD Hi-flex tracks Minimum curvature radius of 750 mm (30") Semi-flexible track Minimum curvature radius of 5 m (16 ft)
Torch type	MIG/MAG, SAW, Plasma, Oxy-fuel
Torch diameter	MIG/MAG 16–22 mm (0.63–0.87") SAW, Plasma up to 35 mm (1.38") option Oxy-fuel
Horizontal pulling force	300 N
Vertical pulling force	200 N
Horizontal speed	10–200 cm/min (4–80 in/min)
Vertical speed	10–200 cm/min (4–80 in/min)
Weight	10 kg (22 lbs)
Product Code (115–230 V, 50–60 Hz, plug EU)	WOZ-0570-10-20-00-0



Continuous welding



Horizontal speed
10–200 cm/min



Vertical speed
10–200 cm/min



Ring tracks from
200 mm (8") OD
up to 3 m (10 ft) OD



Hi Flex Track
min OD 1500 mm (59")



Min. path convex radius
for semi-flexible tracks
is 5 m (16 ft)

Rail Tug can work in various welding positions on both ferromagnetic and non-ferromagnetic materials by using rack and pinion drive and various tracks equipped with magnetic or vacuum units.

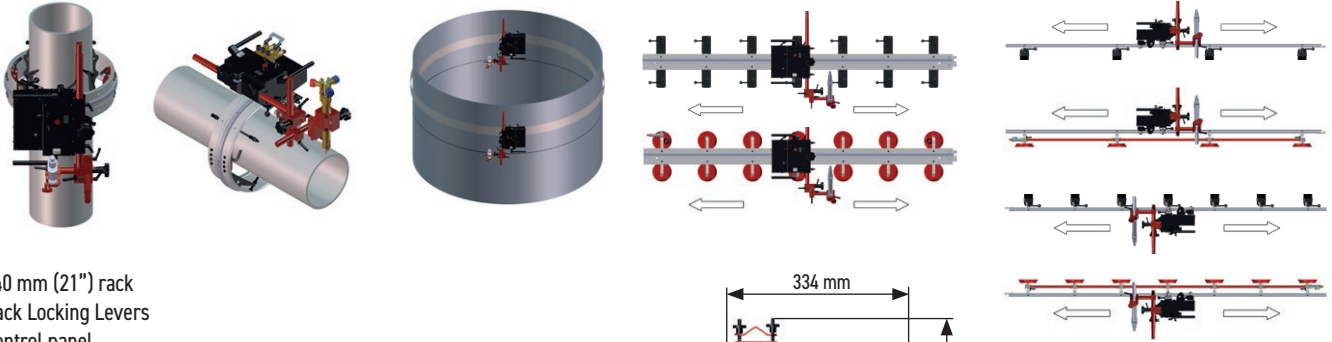



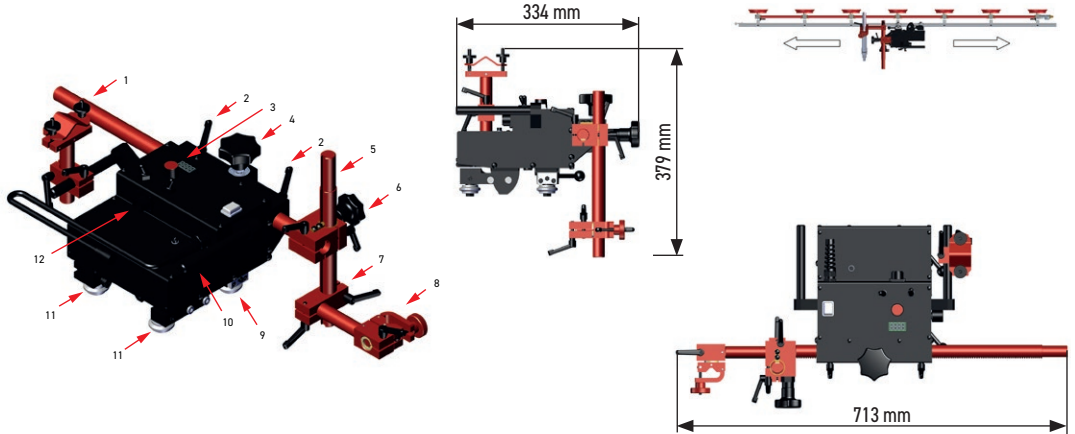











1. 540 mm (21") rack
2. Rack Locking Levers
3. Control panel
4. Rack adjustment knob
5. 300 mm (12") rack with 180 mm (7") adjustment
6. Rack holder
7. Clamping block with levers
8. Short rod torch holder with fits-all clamp
9. Guiding Roller
10. Carrying handle
11. Adjustable Roller
12. Arc ignition socket



Standard accessories:

 Power cord 3 m (9,7 ft) PWD-0466-18-00-00-0 (230 V CEE) PWD-0466-16-00-00-0 (115 V USA) PWD-0466-28-00-00-0 (115 V UK)	 Start-Stop arc ignition cable 6.5 m KBL-0466-17-00-00-0	 540 mm long rod with 449 mm geared rack RAM-0753-07-00-00-0	 300 mm long rod with 182 mm geared rack RAM-0523-17-00-00-0	 Short rod torch holder with clamp 16-22 mm UCW-0754-07-00-00-0
 Cable anchor UCW-0523-05-01-00-0	 Sliding clamping block type I ZSP-0475-62-00-00-0	 Double clamping block with levers KST-0525-11-00-00-0		

Optional accessories:

 Gear Rack Adjustment Tool PKT-0341-13-00-00-0	 700 mm (25.6") long rod with 647 mm geared rack RAM-0475-07-03-00-0	 1000 mm (39.4") long rod with 940 mm geared rack RAM-0753-13-00-00-0	 Counterweight 1.3 kg (2.9 lbs) PWG-0753-09-00-00-0	 Large Counterweight 2,6 kg (5,7lbs) PWG-0753-12-00-00-0	 22-35 mm Torch Clamp ZRZ-0466-19-00-00-0	 203 mm (8") rod KLM-0236-00-16-00-0	 Standard Torch Holder 28-35 mm (1.10-1.38") ZCS-0475-28-10-00-0	 Standard Torch Holder with angle adjustment UCW-0475-28-00-00-0
 Precise torch holder incl. clamp 28-35 mm with angle and height adjustment UCW-0753-08-00-00-0	 Machine torch holder 30 mm (1-3/16") UCW-0475-61-00-00-0	 Machine torch holder 35 mm (1-3/8") UCW-0475-29-00-00-1	 Precise machine torch holder 30 mm (1-3/16") with angle adjustment UCW-0753-22-00-00-0	 Precise machine torch holder 35 mm (1-3/8") with angle adjustment UCW-0753-24-00-00-0				

Standard shipping set:

- Rail Tug tractor
- Cardboard box
- 300 mm (12") rack with 180 mm (7") adjustment
- Rack holder
- Clamping block with levers
- Short rod torch holder with clamp
- Cable anchor
- 6 mm hex wrench
- 6.5 m (21 ft) arc ignition cable
- 3 m (10 ft) power cord
- Operator's Manual

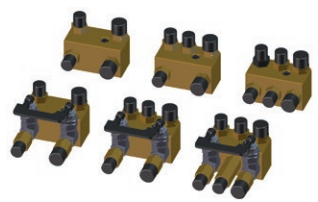

Gas Manifold type	Metric	Imperial
Manifold 2x2	RZD-0475-64-00-00-0	RZD-0475-68-00-00-0
Manifold 2x3	RZD-0475-63-00-00-0	RZD-0475-67-00-00-0
Manifold 3/3	RZD-0475-74-00-00-0	RZD-0475-73-00-00-0
Manifold 2x2 with cut-off valve	RZD-0475-65-00-00-0	RZD-0475-70-00-00-0
Manifold 2/3 with cut-off valve	RZD-0475-66-00-00-0	RZD-0475-69-00-00-0
Manifold 3/3 with cut-off valve	RZD-0475-72-00-00-0	RZD-0475-71-00-00-0



RAIL TITAN 2 | MODULAR TIG-MIG-MAG WELDING AND CUTTING RAIL TRACTOR

Rail Titan 2 is fully modular mechanized tractor that can be custom configured for TIG-MIG-MAG welding, oxy-fuel or plasma cutting and gouging applications on flat or curved plate, tube and pipe.

Linear torch oscillator produces straight, triangle, trapezoid and square weld paths.

Rail Titan 2 can travel on hi-flex, semi-flexible, rigid or ring tracks that can be clamped to ferrous materials with magnetic units and to non-ferrous materials by means of vacuum track system incl. vacuum pump and vacuum units.

Primary features and benefits:

- Suitable for TIG welding (HF resistant)
- Robust design with die-cast aluminum housing
- Ergonomic remote control pendant with simple and easy to find control knobs makes adjustments possible without lifting of the operators welding hood
- Programmable path of stitch welds
- Suitable for variety of circumferential and irregular surface applications down to min. radius of 100 mm (4")
 - Ring tracks on diameters from 200 mm (8") OD up to 3 m (10 ft) OD
 - Hi-Flex tracks on diameters from 1500 mm (59") OD upwards
 - Semi-flexible tracks can be flexed to minimum radius of 5 m (16 ft) without permanent deformation
- Seam tracking enables active compensation of torch position vertically and horizontally with and without oscillation
- Reliable signal sockets/plugs feature increased HF immunity and improved grip for easier tightening & loosening
- Suitable for all welding positions on both ferromagnetic and non-ferromagnetic materials thanks to rack and pinion drive and various tracks equipped with magnetic or vacuum units
- Rail Titan 2 produces consistent high quality welds and cuts in a fraction of the time required by manual operations
- The mirror switch function allows the welder to adjust the torch position to the left or right, regardless of the welder's position relative to the torch
- Wide input voltage range: 100-240V, 50-60Hz 1ph (single phase)

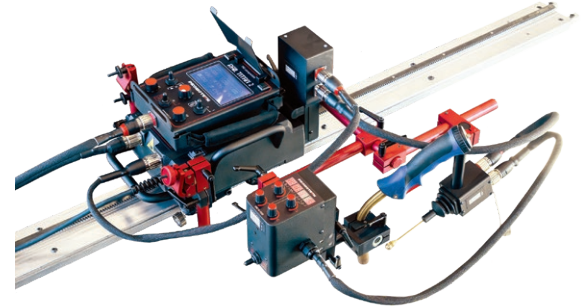
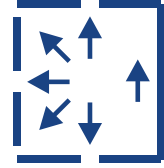

Dimensions:

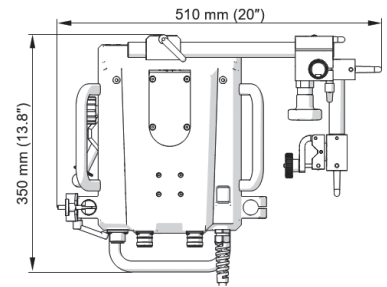
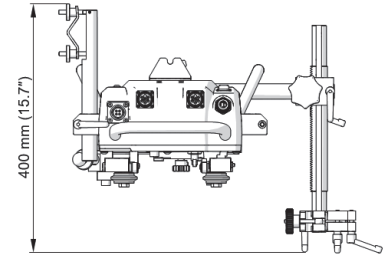

RAIL TITAN 2 TECHNICAL SPECIFICATION		
Voltage	1~100-240V, 50-60Hz	
Power	120 W	
Welding position (according to EN ISO 6947 and AWS/ASME)	Horizontal	PA/1F/1G PB/2F PC/2G PD/4F PE/4G
	Vertical	PF/3G PG/3F (contact your dealer) PG/3G
Fixing on pipes and round workpieces	Ring tracks (OD)	200 mm (8") - 3 m (10 ft)
	Hi-flex tracks (OD)	Minimum 1.5 m (5 ft)
	Hi-flex tracks (ID)	Minimum 3.4 m (11 ft)
	Semi-flex tracks (OD)	Minimum 10 m (32 ft)
Torch type	MIG/MAG, TIG, oxy-fuel, plasma	
MIG/MAG torch diameter	16-22 mm (0.63-0.87")	
Minimum workpiece thickness for magnetic clamping	5 mm (0.2")	
Horizontal pulling force	400 N	
Vertical pulling force	315 N	
Horizontal speed	0-250 cm/min (0-98 in/min)	
Vertical speed	0-250 cm/min (0-98 in/min)	
Oscillation type	Linear	
Weld path	Straight, triangle, trapezoid, square	
Oscillation width	0.1-11.8 cm (0.04-4.5")	
Oscillation speed	10-200 cm/min (5-78 in/min)	
Oscillation dwell time at center and on ends	0-5 s	
Maximum oscillator pulling force	100 N	
Weight (incl. standard accessories)	13 kg (29 lbs)	
Product Code (115-230 V, 50-60 Hz, plug EU)	WOZ-0813-10-20-00-0	

Linear oscillation with trapezoid, triangle, square and straight line paths

Ring tracks from 200 mm (8") OD up to 3 m (10 ft) OD

Hi Flex Track
min OD 1500 mm (5 ft)
min ID 3400 mm (11 ft)

Min. path convex radius for semi-flexible tracks is 5 m (16 ft)

Continuous welding

Stitch welding

Horizontal speed
0-250 cm/min

Vertical speed
0-250 cm/min

Mirror switch

Rail Titan 2 can work in all welding positions on both ferromagnetic and non-ferromagnetic materials by using rack and pinion drive and various tracks equipped with magnetic or vacuum units.

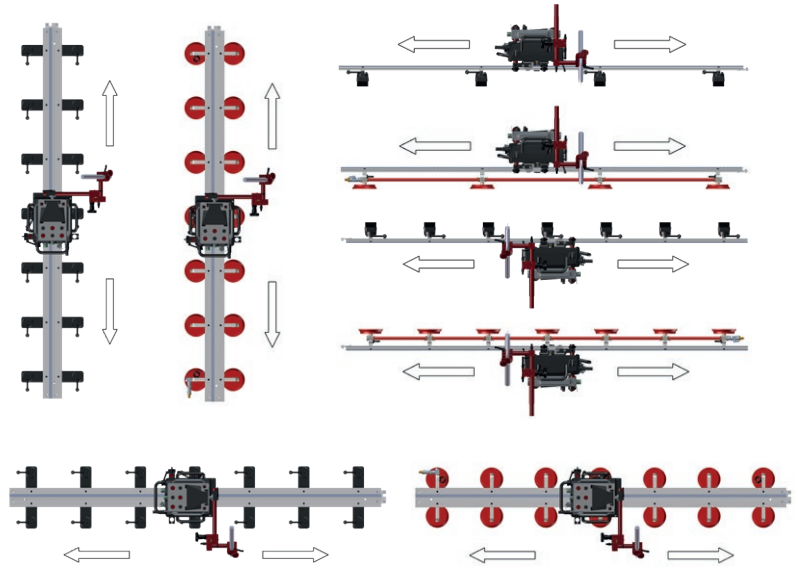
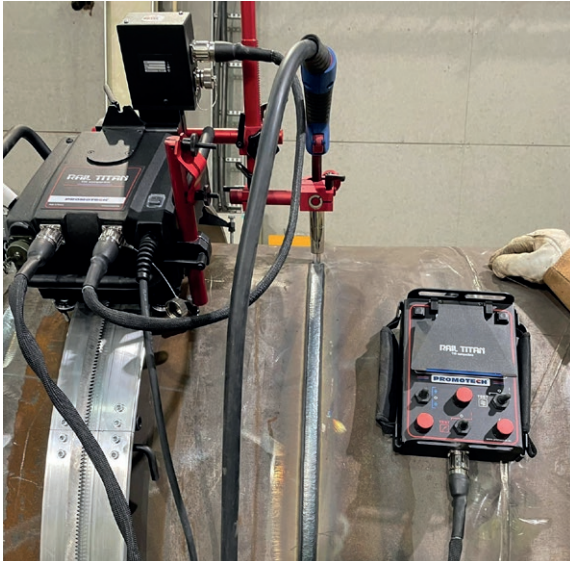

Mirror Switch

The mirror switch function allows the operator to adjust the torch position to the left or right regardless of the welder's position relative to the torch.

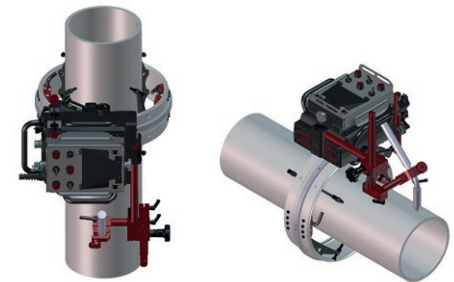
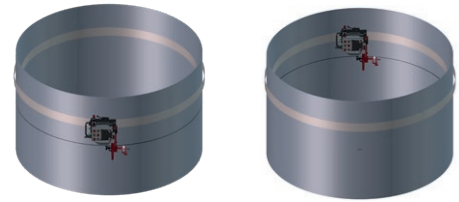

Single lever with lock to position Rail Titan 2 to track

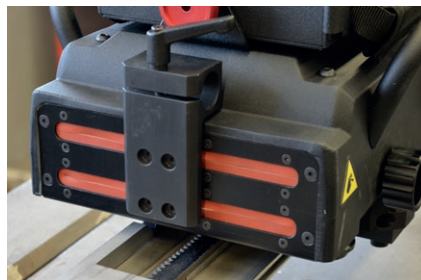

Silicone covers protect against dirt and spatter



Reliable signal sockets and plugs

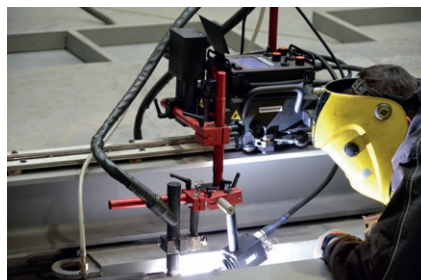

TIG welding of titanium plate



Seam tracking works with and without oscillation

Weld paths

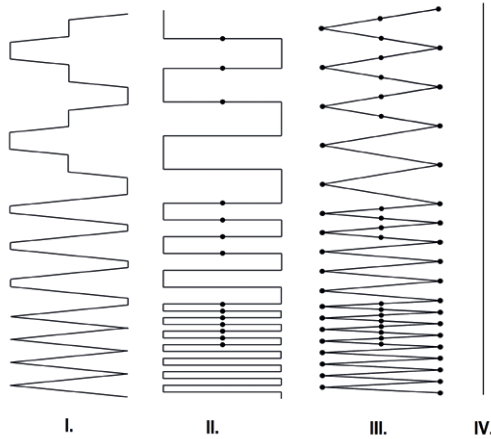

- I. Trapezoid The tractor travels continuously even during dwell mode. Weld path is determined by weave speed and dwell time at center and on sides of the weld path.
- II. Square The tractor travels only during oscillation dwell time in left and right position. During oscillation dwell time in center position the tractor fills the crater.
- III. Triangle The tractor travels only during weaving. Both the tractor and oscillation stop during dwell mode.
- IV. Straight The tractor travels continuously while oscillation is switched-off.

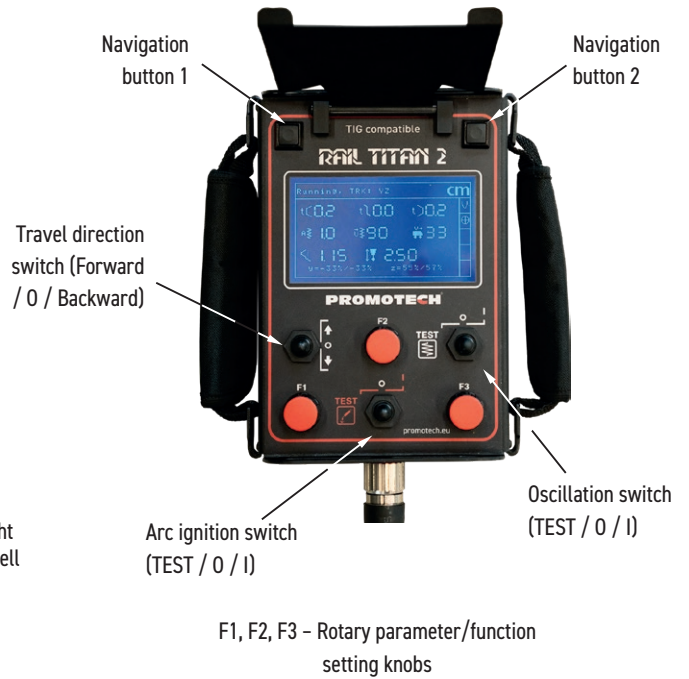

Standard accessories



Optional equipment

Configuration with seam tracking horizontally and vertically requires an optional seam tracking attachment and a motorized vertical slide

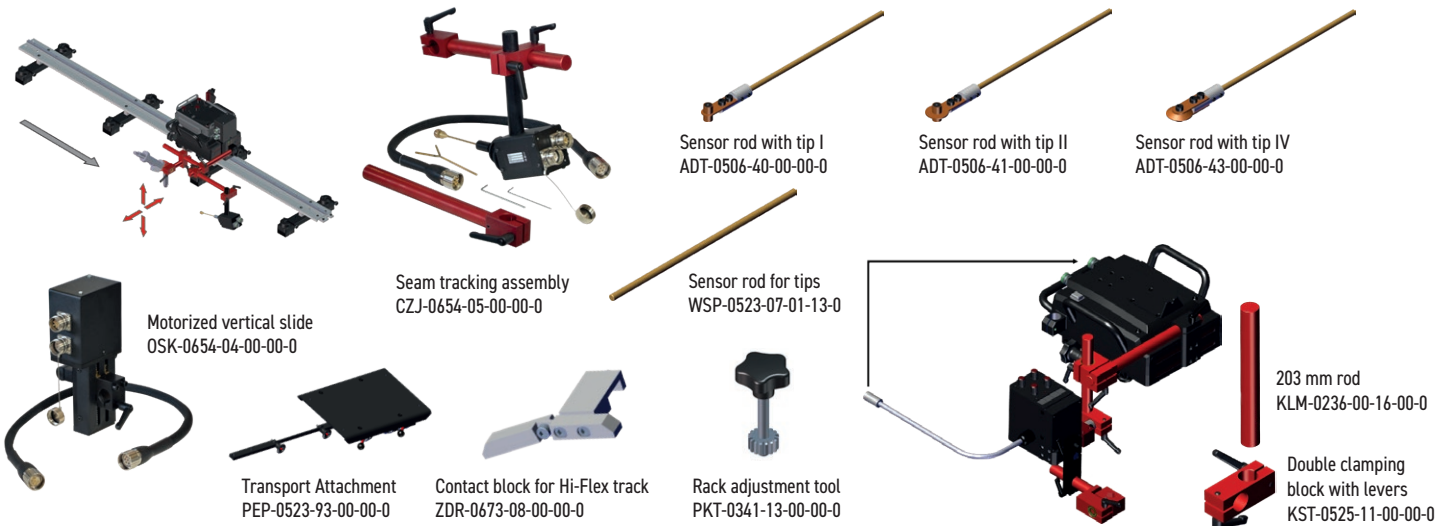

Standard shipping set:

- Rail Titan 2 tractor
- Plastic box
- Remote control pendant
- Set of 3 signal cables
- Power cord
- 6.5 m (21 ft) arc ignition cable
- 300 mm (12") rod
- 300 mm (12") rack with 180 mm (7") adjustment
- Rack holder
- Clamping block with levers
- Short rod torch holder with fits-all clamp
- Cable anchor
- Contact block
- 6 mm hex wrench
- Operator's manual

Applications:

- Trailer manufacturing
- Truck tanks
- Oil tanks
- Water storage tanks
- Pressure vessels
- Vessel overlay / hardfacing
- Bridge girders
- Structural steel
- Structural towers
- Panel welding
- Transformers
- Shipyards
- Any application demanding long continuous welds

Shipping weight: 23 kg. Shipping dimensions (W x L x H): 515 mm x 830 mm x 340 mm

PROMOTECH offers a wide range of tracks suitable for variety of circumferential and irregular surface applications down to min. radius of 100 mm (4")

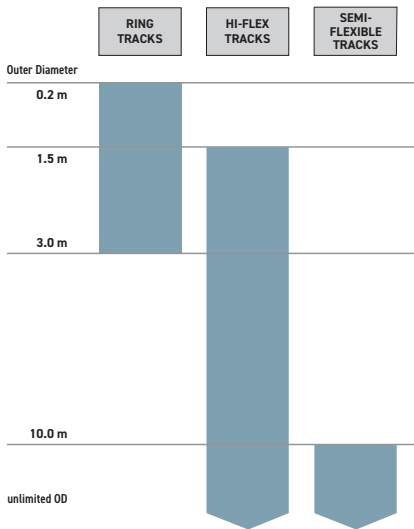

Ring tracks suitable for Rail Titan 2 and Rail Tug

For circumferential applications from 200 mm OD up to 3000 mm OD (from 8" to 10 ft.)



Ring tracks can be equipped with various supports depending on the customer's needs.

Bracket for ring track supports to expand pipe diameter range by 50 mm downwards
DYS-0523-14-14-00-0



Ring track support with bolts
WSP-0654-11-00-00-0

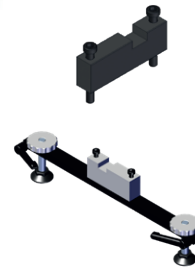

Ring track support with plastic feet
WSP-0654-12-00-00-0

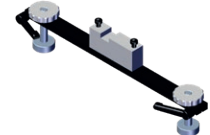

Ring track support with magnets
WSP-0654-13-00-00-0

Hi-Flex track suitable for Rail Titan 2 and Rail Tug

For circumferential applications from 1500 mm (59") OD upwards

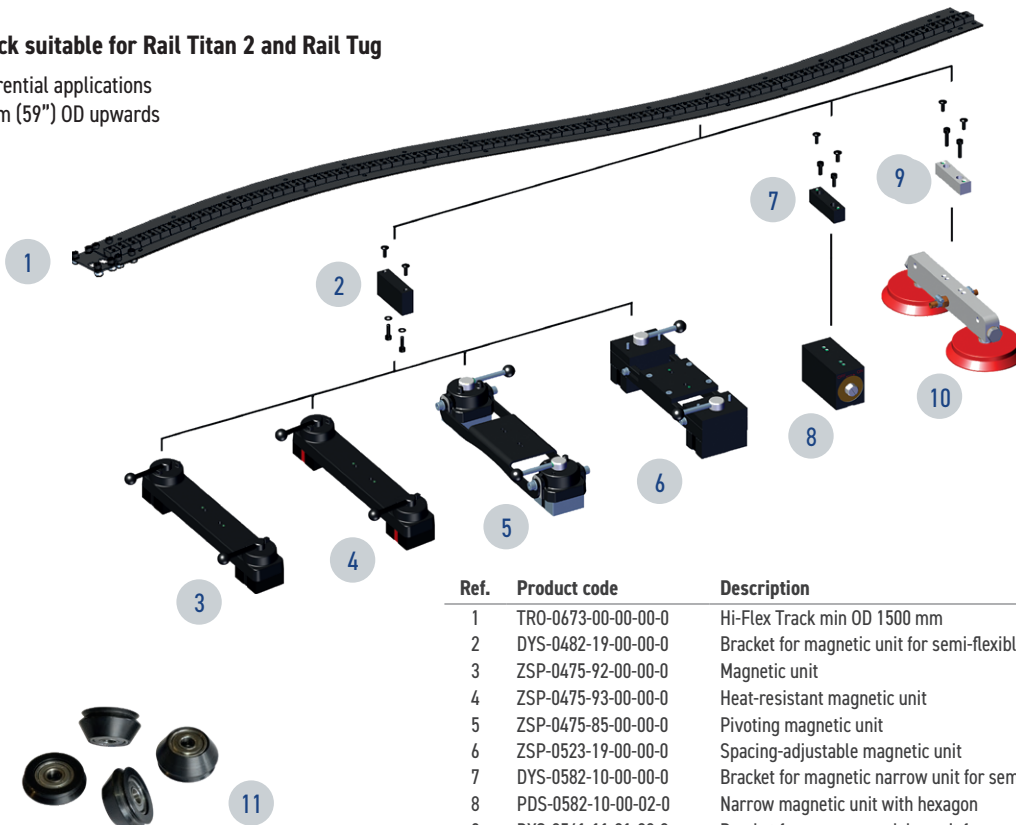

Ref.	Product code	Description
1	TRO-0673-00-00-00-0	Hi-Flex Track min OD 1500 mm
2	DYS-0482-19-00-00-0	Bracket for magnetic unit for semi-flexible track and Hi-Flex track
3	ZSP-0475-92-00-00-0	Magnetic unit
4	ZSP-0475-93-00-00-0	Heat-resistant magnetic unit
5	ZSP-0475-85-00-00-0	Pivoting magnetic unit
6	ZSP-0523-19-00-00-0	Spacing-adjustable magnetic unit
7	DYS-0582-10-00-00-0	Bracket for magnetic narrow unit for semi-flexible track and Hi-Flex track
8	PDS-0582-10-00-02-0	Narrow magnetic unit with hexagon
9	DYS-0541-11-01-00-0	Bracket for vacuum modular unit for semi-flexible track and Hi-Flex track
10	MST-0541-10-02-00-0	Vacuum modular unit
11	ZSP-0673-07-00-00-0	Set of Hi Flex Track Guiding Rollers (4 pcs) for RAIL TUG and RAIL TITAN 2

Semi-flexible tracks

For straight line and circumferential applications.
It can be flexed to minimum radius of 5 m (16 ft) without permanent deformation

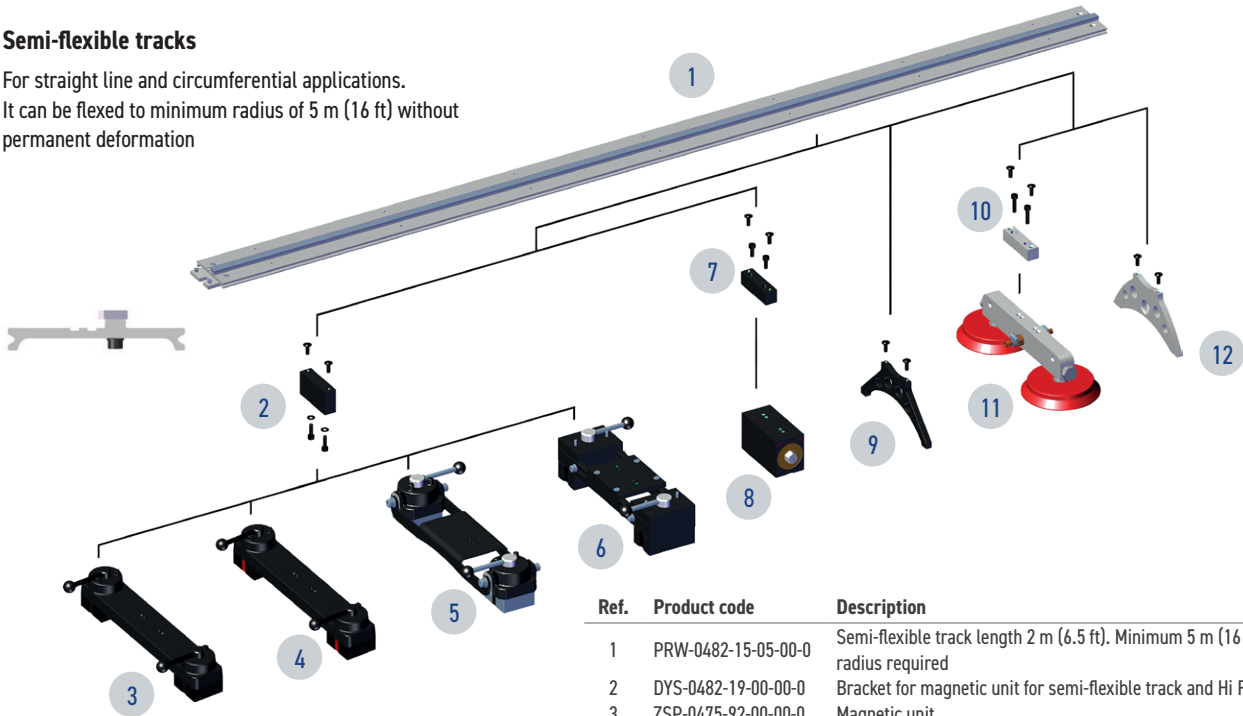

Ref.	Product code	Description
1	PRW-0482-15-05-00-0	Semi-flexible track length 2 m (6.5 ft). Minimum 5 m (16 ft) curvature radius required
2	DYS-0482-19-00-00-0	Bracket for magnetic unit for semi-flexible track and Hi Flex track
3	ZSP-0475-92-00-00-0	Magnetic unit
4	ZSP-0475-93-00-00-0	Heat-resistant magnetic unit
5	ZSP-0475-85-00-00-0	Pivoting magnetic unit
6	ZSP-0523-19-00-00-0	Spacing-adjustable magnetic unit
7	DYS-0582-10-00-00-0	Bracket for magnetic narrow unit for semi-flexible track and Hi Flex track
8	PDS-0582-10-00-02-0	Narrow magnetic unit with hexagon
9	WSP-0523-12-01-00-1	Steel support for semi-flexible track
10	DYS-0541-11-01-00-0	Bracket for vacuum modular unit for semi-flexible track and Hi Flex track
11	MST-0541-10-02-00-0	Vacuum modular unit
12	WSP-0541-11-02-00-0	Aluminum track support for semi-flexible track

Rigid tracks

For straight line applications and for going beyond workpiece and continuous welding edge to edge

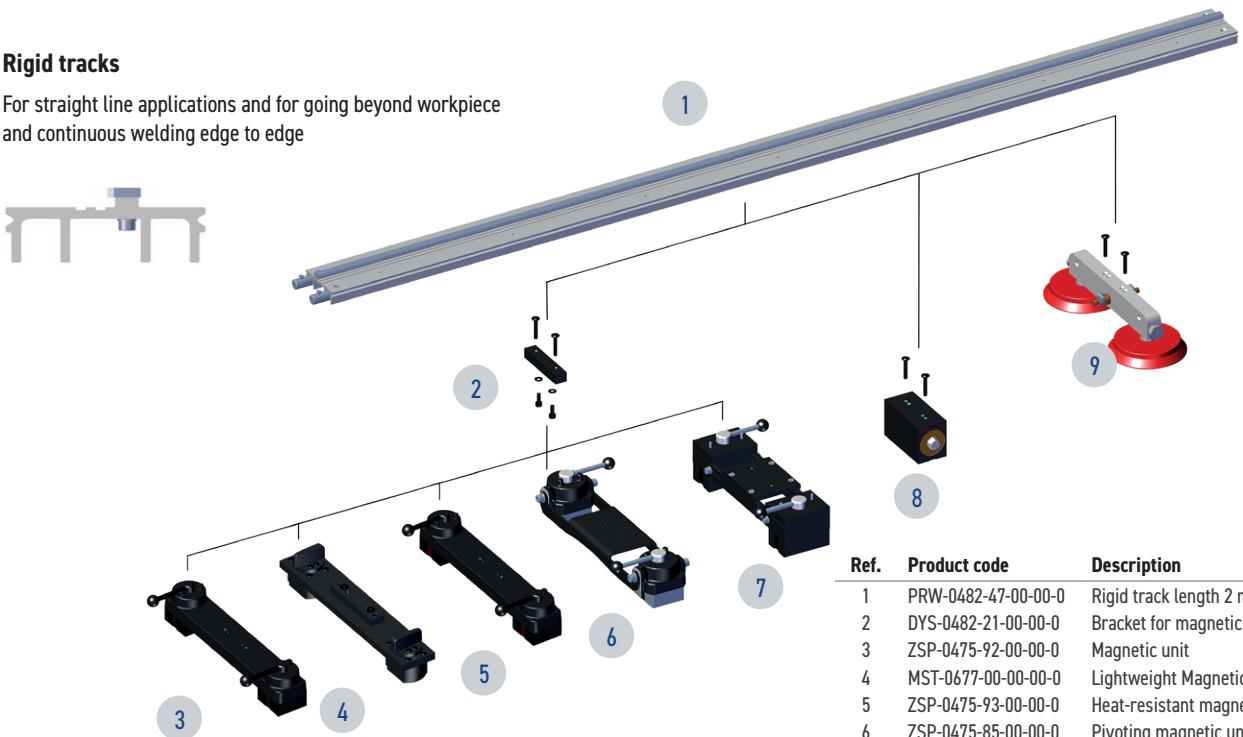

Ref.	Product code	Description
1	PRW-0482-47-00-00-0	Rigid track length 2 m (6.5 ft)
2	DYS-0482-21-00-00-0	Bracket for magnetic units for rigid track
3	ZSP-0475-92-00-00-0	Magnetic unit
4	MST-0677-00-00-00-0	Lightweight Magnetic Unit
5	ZSP-0475-93-00-00-0	Heat-resistant magnetic unit
6	ZSP-0475-85-00-00-0	Pivoting magnetic unit
7	ZSP-0523-19-00-00-0	Spacing-adjustable magnetic unit
8	PDS-0582-10-00-02-0	Narrow magnetic unit with hexagon
9	MST-0541-10-02-00-0	Vacuum modular unit

Optional accessories for variety of applications:



Gear Rack Adjustment Tool
PKT-0341-13-00-00-0

16-22mm Torch Clip
ZCS-0476-06-01-00-0

22-35mm Torch Clamp
ZRZ-0466-19-00-00-0

Transport Attachment
PEP-0482-18-00-00-0

VACUUM TRACK SYSTEM



PROMOTECH's vacuum fixing system provides firm grip of rail tracks on both ferromagnetic and non-ferromagnetic materials.

Lightweight and modular design enables easy adjustment and fitting of the system to specific needs depending on welding or cutting applications and working positions (e.g. flat, horizontal or vertical).

Vacuum fixing system can be applied to both rigid and semi-flexible tracks to enable usage on surface with a radius of more than 5 m (16 ft).

Features

- back up reservoir for added safety in case of a power failure; back up vacuum offers additional time to safely secure a welding tractor and tracks; it also greatly reduces installation time of the whole system
- maximum plate temperature up to +320°C (608°F)
- only 100 mm (4") minimal distance from heat source to vacuum pads

Applications

- welding and cutting of non-ferromagnetic materials (aluminum or stainless steel constructions)
- welding and cutting of thin or coated ferromagnetic materials when magnetic adhesion may be insufficient

Technical specification

PROMOTECH's system consists of a vacuum pump that generates vacuum and of vacuum units that fix the semi-flexible or rigid track to the surface.

A single pump provides gauge pressure sufficient for up to 21 vacuum units.

A single vacuum unit provides suction power of 1400 N (at gauge pressure of -0.7 bar / -10 psig).

The permitted load is up to 30 kg (66 lbs) - welding/cutting tractor with accessories.

Semi-flexible track can be fixed on flat or curved surfaces with a radius of at least 5 meters (16 ft).

An optional manifold can separately connect vacuum units of up to four rails, what allows rail leapfrogging during operation.

Temperature of material on which vacuum pads are used cannot exceed +320°C (608°F).

Heat source must be kept at least 100 mm (4") away from vacuum pads.

Safety eye bolts are provided to suspend vacuum rail tracks and protect them against accidental fall.

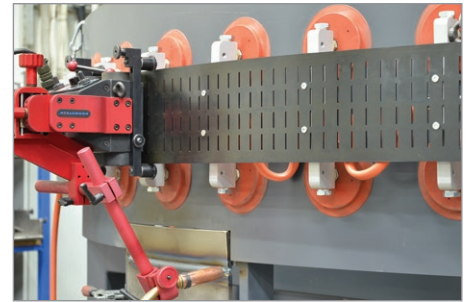

VACUUM TRACK SYSTEM PARAMETERS				
Maximum number of vacuum units per vacuum pump		21		
Minimum curvature radius of semi-flexible track		5 m (16 ft)		
Vacuum unit holding force		1400 N (at gauge pressure of -0.7 bar / -10 psig)		
Working positions		flat, horizontal, vertical		
Maximum permitted track load		30 kg (66 lbs)		
Minimum number of vacuum units	Track type	Horizontal position	Wall position	Curve
	Hi-Flex Track	8	8	8
	Semi-Flex Track	4	7	7
	Rigid Track	4	7	-
Permitted ambient temperature near vacuum units		from -20°C to 200°C (from -4°F to 392°F)		

PORTABLE VACUUM PUMP PARAMETERS	
Voltage	1- 230 V, 50-60 Hz 1- 115 V, 50-60 Hz
Power	400 W
Gauge pressure obtainable	-0.8 bar (-11.5 psig) (where 0 is for atmospheric pressure, and -1 is for perfect vacuum)
Pump capacity	4 m ³ /h (141 ft ³ /h)
Ambient temperature	0-40°C (32-104°F)
Safety reservoir volume	10 l (0.35 ft ³)
Weight (with safety reservoir)	23 kg (51 lbs)

Portable vacuum pump with safety reservoir



- generates vacuum and supports up to 21 vacuum units
- AGR-0541-10-20-00-0 for 230 V
- AGR-0541-10-10-00-0 for 115 V with UK plug

Modular vacuum unit may perform various functions and can be easily configured in 4 different ways as



Modular vacuum unit
 • consists of 2 vacuum pads and manifold block
 MST-0541-10-02-00-0



entry unit



middle unit



extension unit



end unit



Vacuum pad (spare part)
 SSW-0541-99-01-00-0

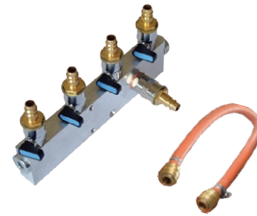

4-way manifold with connection cable
 • can separately connect vacuum units of up to four rails
 • allows rail leapfrogging during operation
 ROZ-0541-04-00-00-0



Pump connection hose
 • connects pump to entry vacuum unit
 (10 m / 33 ft)
 PWD-0541-06-00-00-0



Cut-off valve (for entry vacuum unit)
 ZWR-0541-10-01-30-0



Threaded plug (for end vacuum unit)
 KRK-0541-99-00-00-0



Hose clamp
 OPS-000005



2-meter / 7-foot hose
 • for interconnecting vacuum units within rail tracks
 • 1 per rail track
 • should be cut to the required length
 PWD-0541-10-07-00-0



Coupled hose
 • for interconnecting vacuum units of different rail tracks
 • 1 per additional rail track (serial connection)
 PWD-0541-10-04-00-0



Quick coupling
 SZB-000018



Hose fitting
 KRC-000013



Hose extension adapter
 LCZ-0541-05-00-00-0



Safety eye bolt
 SRB-000365

Track elements



Hi Flex Track
 min OD 1500 mm
 TRO-0673-00-00-0



Semi-flexible track
 length 2 m (6.5 ft)
 PRW-0482-15-05-00-0

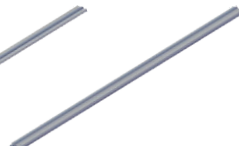

Rigid track length
 2 m (6.5 ft)
 PRW-0482-47-00-00-0



Bracket for vacuum modular unit for semi-flexible track and Hi Flex track
 DYS-0541-11-01-00-0



160 mm wide flexible track
 length 1.88 m (6.1 ft).
 PRW-0466-71-00-00-0



Bracket for vacuum modular unit for 160 mm wide flexible track
 DYS-0466-71-04-00-0

System configuration for serial connection

System includes:

- Entry vacuum unit (1 unit per rail track)
- Middle vacuum units (up to 5 units per rail track)
- Extension vacuum unit (for serial connection)

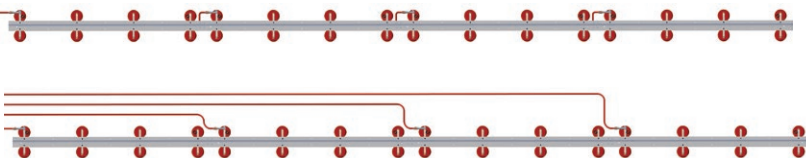

4 vacuum units are required per rail track placed in horizontal position



7 vacuum units are required per rail track placed on walls or curvatures

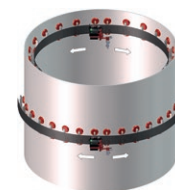

Vacuum units in use on stainless steel or aluminum tanks



Minimal OD is 10 m (32 ft)

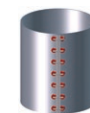

Minimal OD is 3 m (10 ft)

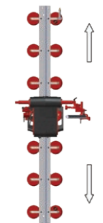



DRAGON | CUTTING TRACK TRACTOR

Dragon is intended to transport different types of oxy-fuel cutting torches with a grip diameter 28-35mm (1-1/8" to 1-3/8") to perform machine quality cutting and beveling processes in a variety of applications.

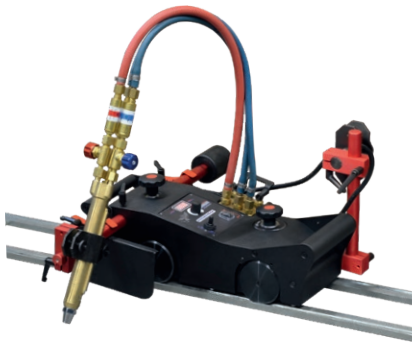

DRAGON
Cutting tractor for Oxy-Fuel

42V AC version available



DRAGON HS
Cutting tractor for plasma

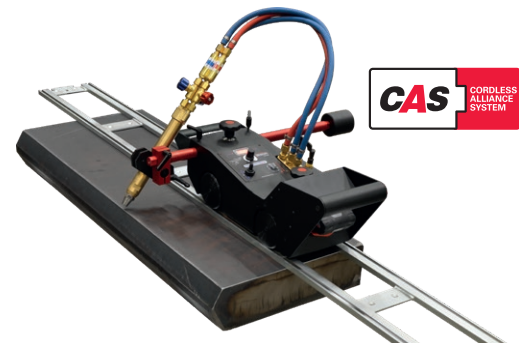

DRAGON BATTERY
Cordless cutting tractor

Common features and benefits of the DRAGON family:

- Oxy-fuel and plasma cutting
- Digital speed control and stabilization for high quality cuts
- Cutting and bevelling up to 45° (also parallel, using 2 torches)
- LED display with readouts of both actual and set speeds, as well as report messages
- Runs on a rail or directly on a workpiece
- Quick drive release switch for easy re-positioning
- Ergonomic handles on both sides make it easy to carry the tractor
- Wide assortment of optional accessories like machine barrel torch holders, manifolds, circle cutting attachment make it useful for variety of applications.
- Track sections can be joined together for the required run length
- The tracks can be fixed on both ferrous and non-ferrous materials by means of magnetic or vacuum units
- Various power supply options: 115–230 V, 50–60 Hz, 42V AC or 18V DC battery

DRAGON HS more:

- High travel speed of up to 300 cm/min to increase plasma cutting capacity

DRAGON BATTERY more:

- Ideal for use in the field - no need for mains power and one less cable to carry around
- Convenient 18 V DC battery supply (same 4.0 Ah battery as other PROMOTECH battery-powered tractors)
- The LiHD battery, supported by intelligent battery management, ensures maximum power availability for an extended period



TECHNICAL SPECIFICATIONS			
	Dragon	Dragon HS	Dragon Battery
Voltage	1~ 115-230 V, 50-60 Hz 42 V, 50-60 Hz	~ 115-230 V, 50-60 Hz	18 V DC, 4 Ah
Power	20 W	20 W	20 W
Operating position	horizontal	horizontal	horizontal
Torch diameter	28-35 mm (1.10-1.38")	28-35 mm (1.10-1.38")	28-35 mm (1.10-1.38")
Ground clearance	8 mm (0.31")	8 mm (0.31")	8 mm (0.31")
Speed	0-150 cm/min (0-59 in/min)	10-300 cm/min (4-118 in/min)	0-150 cm/min (0-59 in/min)
Weight	16.8 kg (37.0 lbs)	16.8 kg (37.0 lbs)	15.2 kg (33.5 lbs)
P. Code (115-230 V, 50-60 Hz, plug EU)	WOZ-0475-10-20-00-3	WOZ-0527-10-20-00-1	-
P. Code (115-230 V, 50-60 Hz, plug UK)	WOZ-0475-10-10-00-3	WOZ-0527-10-10-00-1	-
P. Code (42 V, 50-60 Hz)	WOZ-0711-10-04-00-0	-	-
P. Code (18 V DC, 4 Ah)	-	-	WOZ-0788-10-00-00-0

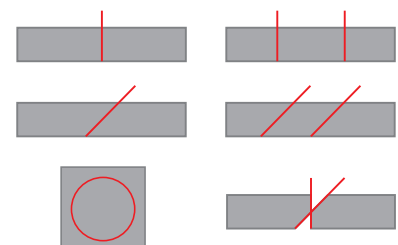

■ Standard accessories for both Dragon, Dragon HS and Dragon Battery



540 mm long rod
with 449 mm geared rack
RAM-0753-07-00-00-0



Counterweight 1.3 kg (2.9 lbs)
PWG-0753-09-00-00-0



Standard Torch Holder
with angle adjustment
UCW-0475-28-00-00-0



Battery 4.0 Ah (Dragon Battery only)
AKM-0738-10-00-01-0
(2 pcs included)

■ Optional accessories for both Dragon, Dragon HS and Dragon Battery



1000 mm (39.4") long rod
with 940 mm geared rack
RAM-0753-13-00-00-0



Large Counterweight
2,6 kg (5,7lbs)
PWG-0753-12-00-00-0

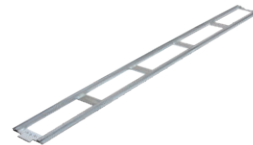

Track Assembly 1800 mm (70,9")
V" Groove Center Line 152 mm (6")
TR0-0475-13-00-00-0

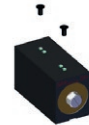

Magnetic Narrow Unit
with hexagon
PDS-0582-10-00-02-0



Magnetic unit
ZSP-0475-92-00-00-0



Lightweight Magnetic Unit
MST-0677-00-00-00-0



Heat-resistant magnetic unit
ZSP-0475-93-00-00-0

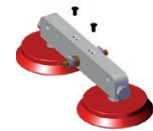

Vacuum Modular Unit
MST-0541-10-02-00-0

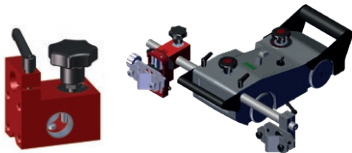

Sliding clamping block type 2
UCW-0475-15-00-00-1

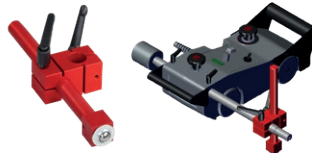

Roller Support
PDT-0475-26-00-00-0



Precise torch holder incl. clamp 28-35 mm
with angle and height adjustment
UCW-0753-08-00-00-0



Standard Torch Holder
28-35 mm (1.10-1.38")
ZCS-0475-28-10-00-0

Circle Cutting Attachment
for 240-1000 mm (9 29/64"-39 3/8") radius
CYR-0475-22-00-00-0

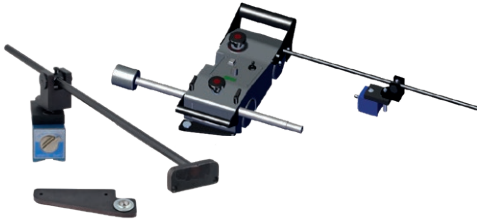

Cable Anchor
PDT-0475-34-00-00-0

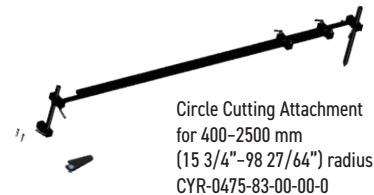

Circle Cutting Attachment
for 400-2500 mm
(15 3/4"-98 27/64") radius
CYR-0475-83-00-00-0



Heat Protection Shields
left: OSL-0475-54-00-00-0
right: OSL-0475-55-00-00-0



Enlarged Battery Shield
(Dragon Battery only)
OSL-0788-08-00-00-0

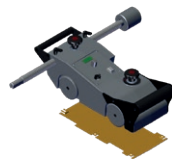

Heat Protection Shield
(bottom)
OSL-0753-20-00-00-0



Battery Charger
(Dragon Battery only)
LDW-0738-10-00-30-0 (EU)
LDW-0738-04-00-30-0 (UK)



Battery 10.0 Ah
(Dragon Battery only)
AKM-0738-10-00-02-0

Optional accessories for Oxy-fuel

Gas Manifold type	Metric	Imperial
Manifold 2x2	RZD-0475-64-00-00-0	RZD-0475-68-00-00-0
Manifold 2x3	RZD-0475-63-00-00-0	RZD-0475-67-00-00-0
Manifold 3/3	RZD-0475-74-00-00-0	RZD-0475-73-00-00-0
Manifold 2x2 with cut-off valve	RZD-0475-65-00-00-0	RZD-0475-70-00-00-0
Manifold 2/3 with cut-off valve	RZD-0475-66-00-00-0	RZD-0475-69-00-00-0
Manifold 3/3 with cut-off valve	RZD-0475-72-00-00-0	RZD-0475-71-00-00-0

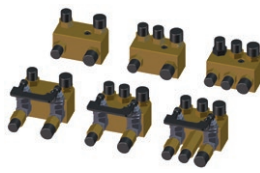

Gas manifold bracket for DRAGON family
PDT-0475-87-00-00-0



Machine torch holder 30 mm (1-3/16")
UCW-0475-61-00-00-0

Machine torch holder 35 mm (1-3/8")
UCW-0475-29-00-00-1

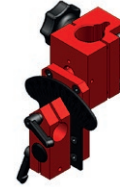

Precise machine torch holder 30 mm (1-3/16") with angle adjustment
UCW-0753-22-00-00-0

Precise machine torch holder 35 mm (1-3/8") with angle adjustment
UCW-0753-24-00-00-0

Optional accessories for Plasma (Dragon HS)



Plasma Arc Ignition
ZSP-0475-58-00-00-0



Arc ignition cable for plasma
KBL-0475-58-05-00-0



New control system of battery pack:

Detection and supervised parameters:

- too low and too high voltage
- too low and too high temperature
- failure of the temperature sensor
- internal battery failure

Benefits:

- over discharge protection
- extended battery life
- high level of safety for both tractor and operator

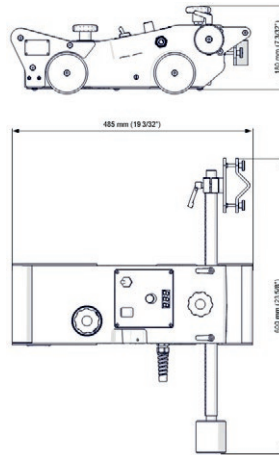

DRAGON / DRAGON HS

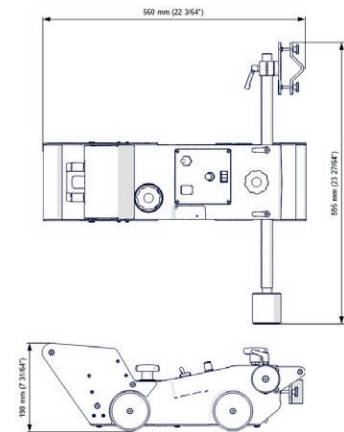

DRAGON BATTERY

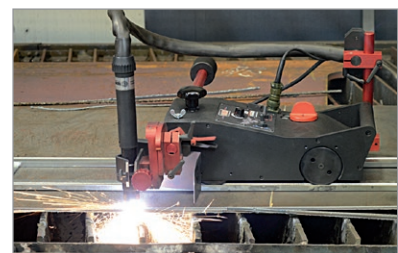
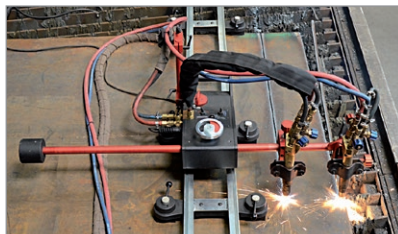

Stay connected



Follow us on our social media to discover how our machines and solutions can boost your industrial processes



PROMOTECH International

- Expert insights
- Hands-on knowledge
- Industry trends & innovations
- Inspiring applications
- Real-world case studies
- Tips & tricks
- and more

Don't miss a thing



PRO-40 PBS | Stationary Pipe Beveling Machine



SCORPIO BATTERY: Advanced Battery-Powered Welding Tractor



ABM-50 DD Vario | Auto-Feed Heavy Duty Beveler



PROMOTECH MCM | 5-Axis CNC Machine- Revolutionize Wind Tower Door Frame...

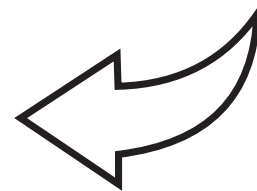

Check our **BLOG** for expert insights, practical guides and product news

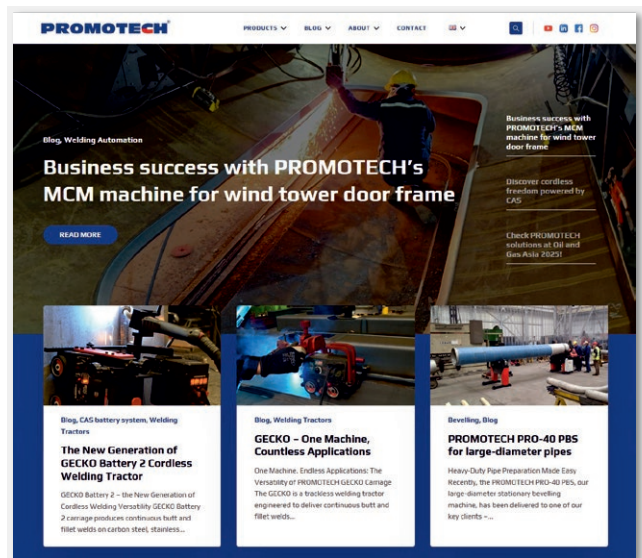

PROMOTECH Sp. z o.o.
ul. Elewatorska 23/1
15-620 Białystok
POLAND

Phone: +48 85 678 34 05
marketing@promotech.eu
www.promotech.eu

PROMOTECH DEUTSCHLAND GmbH
Riedweg 11
D-88339 Bad Waldsee/Gaisbeuren
DEUTSCHLAND

Phone: +49 7524 9700-55
dach@pdg.promotech.eu
www.promotech-deutschland.de

PROMOTECH ME (FZE)
P6-111, Saif Zone
P.O. Box. 514914
Sharjah, UAE

Phone: +9716 552 9493
akumar@pme.promotech.eu
www.promotechme.ae

PROMOTECH Fabrication Machines Pvt. Ltd.
Head Office: Plot 231, Phase-5, Sector 53
I/E HSIIDC Kundli, Sonipat
Haryana-131028, INDIA

Phone: +91 966 766 0304
info@pfm.promotech.eu
www.promotech-india.in

smart tools for heavy tasks

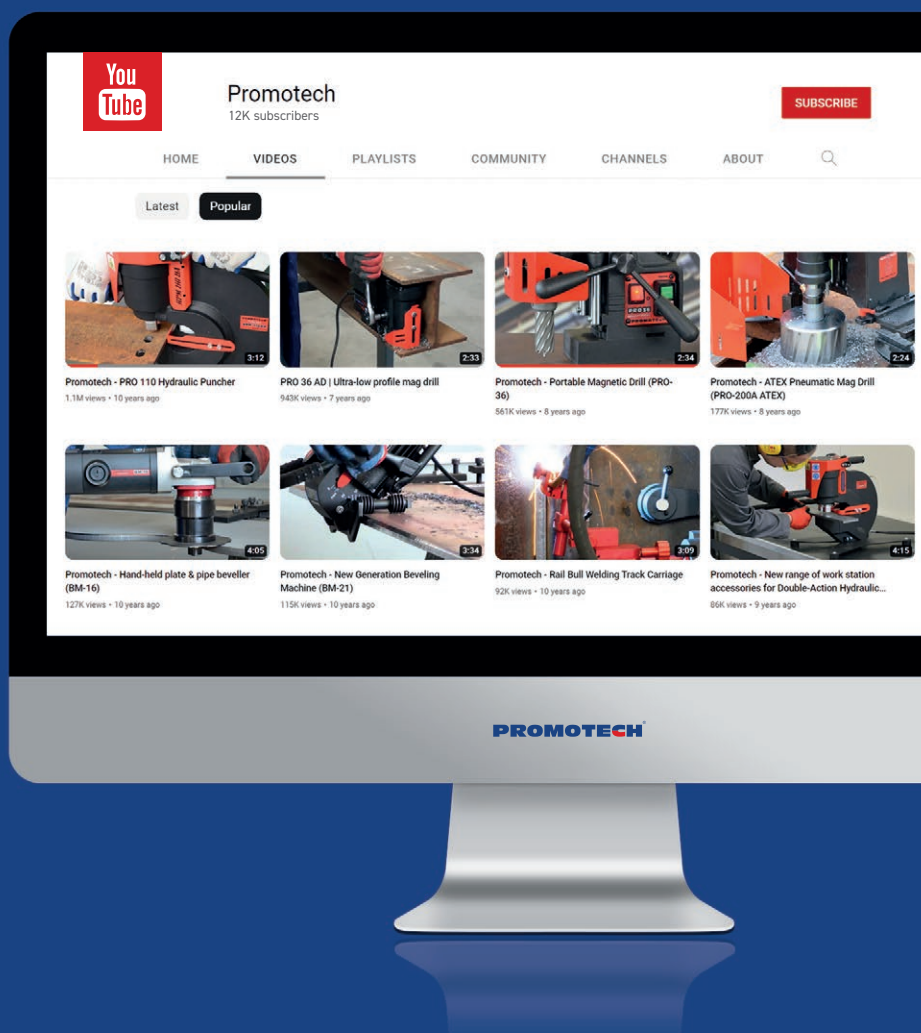

FOLLOW US FOR UPDATE AND MORE

www.promotech.eu

PROMOTECH[®]



FM 37982



Mitglied im DVS – Deutscher Verband für
Schweißen und verwandte Verfahren e. V.



American Welding Society
Supporting Company Member

Your local dealer: