

■ PRO-36R Battery | CORDLESS RAIL DRILLING MACHINE

This battery-operated, very powerful, compact and lightweight rail drilling machine is a perfect solution for outdoor work in remote areas, where no power supply is available.

Fast positioning, quick clamping and instant unlocking mechanisms make it easy to use and safe device.

PRO-36R Battery enables drilling in rails of any standard by means of 2 pcs of optional rail profile templates and 1 pc of hole center positioner, to be chosen by customers from a comprehensive range of auxiliary accessories dedicated to a variety of types of rails.



Battery 4.0 Ah



Battery 5.5 Ah



Battery 10.0 Ah



Battery charger

Charging time
~ 30 min (4.0 Ah)
~ 41 min (5.5 Ah)
~ 74 min (10.0 Ah)



Core drill:
max 36 mm
(1-7/16")



Twist drill:
max 16 mm (5/8") with
Weldon Shank 19 mm (3/4")



Depth of cut:
up to 30 mm
(1-3/16")



Stroke:
40 mm
(1-9/16")



Speed:
350 rpm



Power:
1020 W



Weight:
14.5 kg
(32 lbs)





PRO-36R BATTERY TECHNICAL SPECIFICATION	
Motor Speed (under load)	260 rpm
Power	450 W
Weight	14.5 kg
Max milling capacity	36 mm (1.42")
Max drilling capacity	16 mm?
Stroke	40 mm (1.57")
Max depth of cut	30 mm (1.18")
Voltage	18 V DC
Tool holder	19 mm (3/4") Weldon
Product Code:	

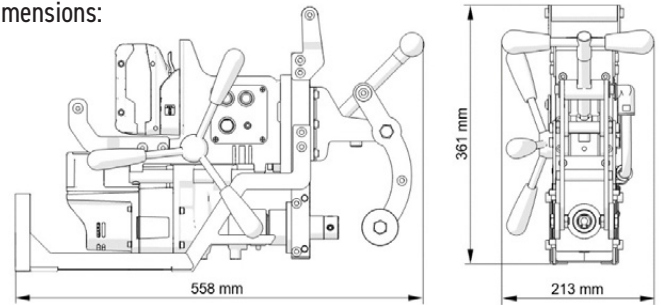

Dimensions:



PRO-36R Battery is equipped with LED monitoring system that generates signals in green and red colors to indicate current condition of the drill.

 CONDITION OF THE DRILL		Ready to Operate. <i>Solid Green</i>
		Emergency stop (overload, clamping loss). <i>Red Flashes</i>
		Motor doesn't turn on. Replace discharged battery. <i>Solid Red</i>



Control panel is equipped with so called „vandal resistant“ illuminated start/stop motor buttons.

Rail profile templates and hole centre positioner are to be ordered, separately.

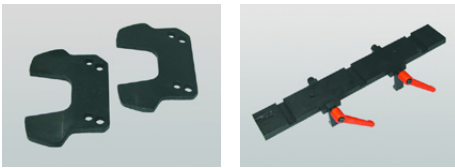

Upon customer's request any rail profile templates and hole centre positioners are subject to manufacture to meet any required rail standard.

Standard shipping set:

- Cordless Rail Drilling Machine
- Plastic Box
- Handle (3 pcs)
- Pressure Coolant 0.5l Bottle Assembly with Adapter
- Allen wrench hex s=4
- Allen wrench hex s=5
- Operator's Manual

Selected additional accessories:

- | | |
|-----------------------|--|
| • UST-0275-00-01-00-0 | S49 Rail Profile Template |
| • UST-0275-00-02-00-0 | UIC 60 Rail Profile Template |
| • UST-0275-00-03-00-0 | P50 Rail Profile Template |
| • UST-0275-00-04-00-0 | P65 Rail Profile Template |
| • UST-0275-00-06-00-0 | NP46 Rail Profile Template |
| • UST-0275-00-07-00-0 | UIC54 Rail Profile Template |
| • WZR-0275-99-00-00-0 | S49 Hole Centre Positioner |
| • WZR-0275-14-00-00-0 | UIC 60 Hole Centre Positioner |
| • WZR-0275-15-00-00-0 | P50 Hole Centre Positioner |
| • WZR-0275-16-00-00-0 | P65 Hole Centre Positioner |
| • WZR-0275-23-00-00-0 | NP46 Hole Centre Positioner |
| • WZR-0275-24-00-00-1 | UIC54 Hole Centre Positioner |
| • ZSP-0275-38-00-00-0 | Double-sided counter-sinking tool Ø 36mm (1 7/16") |



Pressure Coolant 5l Bottle Assembly with Adapter
PJM-0676-10-00-00-0



PROMOTECH Sp. z o.o.
ul. Elewatorska 23/1, 15-620 BIAŁYSTOK, POLAND
tel. (+48 85) 678 34 05, fax (+48 85) 662 78 77
marketing@promotech.eu www.promotech.eu

Your local dealer:

