

## PRO-122T SB | INDUSTRIAL TAPPING & DRILLING MACHINE WITH SWIVEL BASE

The PRO-122T SB machine is designed for industrial hole making and tapping applications.

Powerful variable speed motor enables milling capacity up to 120 mm (4-3/4") and drilling capacity up to 31.75 mm (1-1/4").

Machine's forward & reverse work modes allow thread cutting up to M30 with Promotech's new tapping system.

The PRO-122T SB has a swivel base which makes it much easier to align the pilot pin or twist drill for accurate drilling to avoid off-center holes, especially when used upside down or sideways.













Four speed gearbox with continuous speed adjustment allows to set the optimal speed depending on diameter, steel grade or tool quality. Intelligent speed control system maintains constant motor speed regardless of changing loads.

Innovative 360-degree LED indicator facilitates proper machine operation and increases work safety.

### Features and benefits:

- Swivel base enables local displacement of the machine to facilitate precise hole positioning
- The most powerful motor in its class (among MT3 drills) with heavy duty 4-speed gearbox
- Electronic Speed Stabilization System (ESSS) maintains stable speed regardless of load changes
- tapping of through and blind holes
- milling with TCT or HSS cutters or drilling
- electronic clutch
- both overload and overheat protection
- rigid design extends tool life
- tilt sensor stops the motor if machine breaks away
- 360-degree visual monitoring system indicates current condition of the drill and gives safety and diagnostic information e.g. worn brushes
- innovative smart magnet with reduced weight
- Magnetic Field Shape Control (MFSC) provides maximum holding power on thin materials
- Energy Saving Base (ESB) uses only 50% of its power when motor is not running
- Semi-automatic gib adjustment enables simple, fast, correct and repeatable slide backlash settings without any expert knowledge or experience
- intuitive control panel at top of the drill
- large coolant container



												
Core drill max 120 mm (4-3/4")	Twist drill max 31.75 mm (1-1/4")	Spindle MT3	Depth of cut 100 mm (4")	Stroke 225 mm (9")	Speed 75-110 rpm 135-200 rpm 220-320 rpm 390-570 rpm	Power 2300 W	Weight 28.5 kg (63 lbs)	Thread cutting M30 (1-1/4")	Worn brushes indicator	Thermal /overheat protection	Overload protection	Magnet detachment safeguard

- Reduce fatigue, increase productivity and facilitate accurate hole placement with the PRO-122T SB. With its swivel base, you can move the pilot pin or twist drill until it 'click' into the punch mark to align the tool for precise drilling.

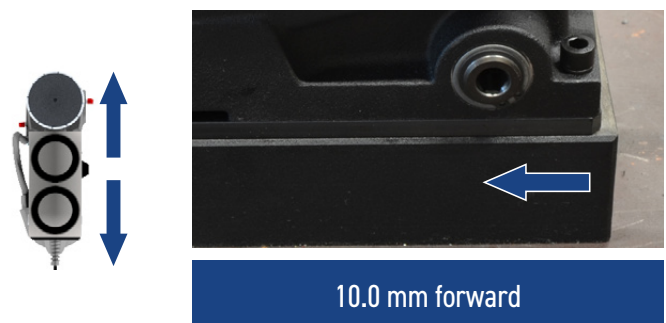
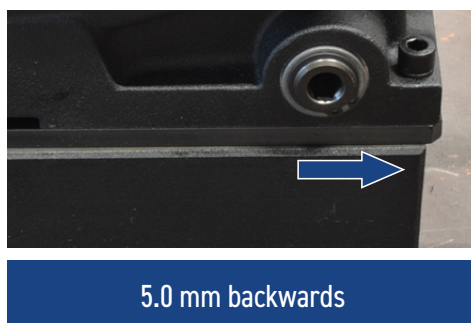
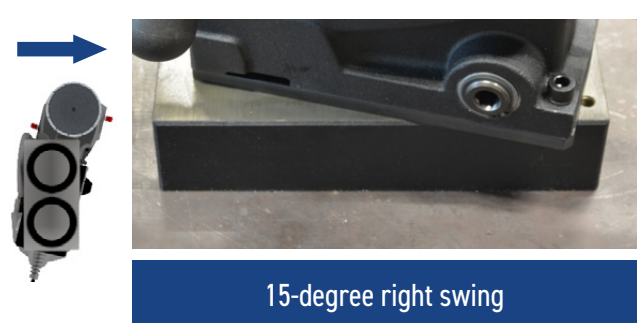
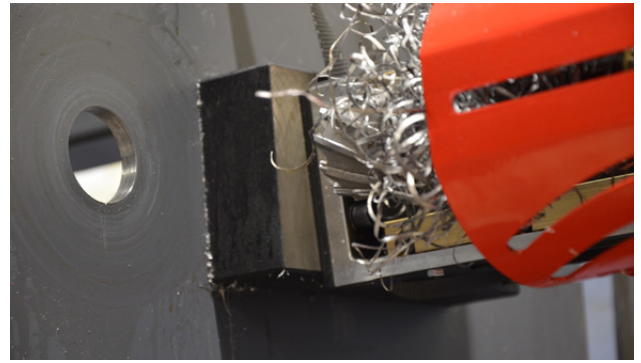

**PRO-122T SB performance**















Milling capacity up to 120 mm (4-3/4")



Drilling capacity up to 31.75 mm (1-1/4")  
Max stroke up to 225 mm (9")

**360-degree Visual Monitoring System – VMS**



 <b>CONDITION OF THE DRILL</b>		Ready to Operate (Solid Green)
		Normal Operation (Solid White)
		Motor Overheat (Solid Red)
		Emergency Stop/Overload Condition (Solid Blue)
		Emergency Stop/Low Adhesion (Solid Violet)
 <b>SAFETY INFORMATION</b>		Inadequate Adhesion (Flashing Green)
		Near Overload (Flashing Blue)
 <b>DIAGNOSTIC INFORMATION</b>		Emergency Stop/Voltage Drop (Red Flashes to Blue)
		Emergency Stop/Worn Brushes (Red Flashes to Green)

**Promotech introduces quick change tapping system including:**

**PRO-122T SB - Available tapping configurations**



- TC – Tapping chucks with securing nut
- TA – Tapping Adapters for through holes
- TASC – Tapping Adapters Safety Clutch for blind holes
- RA – Reduction Adapters

Tapping tool	Tapping chucks		
	MT3-19	MT3-31	MT3-48
M8	TA-1 or TASC-1	TA-1 or TASC-1 along with optional RA 2/1	TA-1 or TASC-1 along with optional RA 3/1
M10			
M12			
M8	TA-2 or TASC-2	TA-2 or TASC-2 along with optional RA 3/2	TA-2 or TASC-2 along with optional RA 3/2
M10			
M12			
M14			
M16			
M18			
M20	TA-3 or TASC-3	TA-3 or TASC-3	TA-3 or TASC-3
M14			
M16			
M18			
M20			
M22, M24			
M27			
M30			

Standard tapping configuration

Optional tapping configuration

**■ Promotech quick change tapping system accessories suitable for PRO-122T SB drilling machine:**

**TC – Tapping chucks with securing nuts**

Product Code	Type	Description
OPR-0584-11-00-00-1	MT3-19	Tapping chuck MT3 x 19 mm
OPR-0584-08-00-00-1	MT3-31	Tapping chuck MT3 x 31 mm
OPR-0584-02-00-00-1	MT3-48	Tapping chuck MT3 x 48 mm



Tapping chuck equipped with securing nut protects tapping tool against pull out



Shipping set of tapping chuck incl. HD-CUT OIL1

**RA – Reduction Adapters**

Product Code	Type	Description
RDC-000008	RA 2/1	Reduction Adapter 2/1 (31 mm / 19 mm)
RDC-000009	RA 3/1	Reduction Adapter 3/1 (48 mm / 19 mm)
RDC-000010	RA 3/2	Reduction Adapter 3/2 (48 mm / 31 mm)



**■ Intuitive control panel at top of the drill**

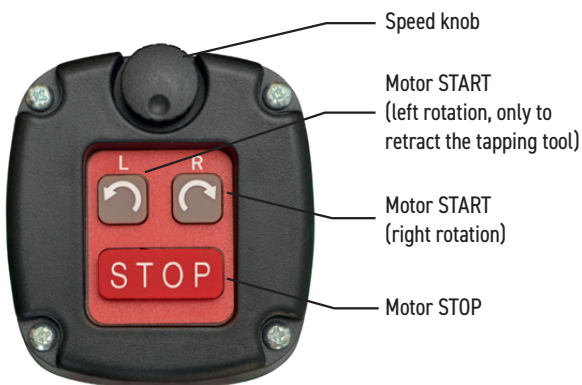

Counterclockwise (CCW) rotation  
User-friendly control of tapping tool retract

**Through hole tapping up to M30**



Tapping chuck - TC

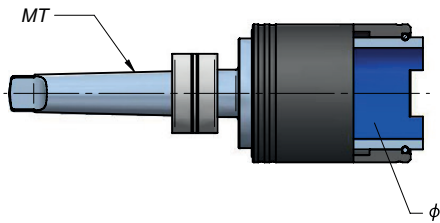

Tapping adapter - TA

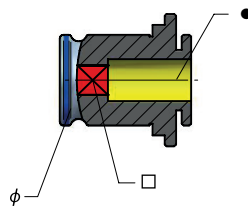

Tapping tool

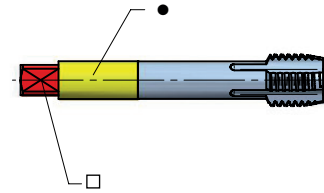

**TA – Tapping Adapters**

Product Code	Type	Description	∅ [mm]	Tap size	● [mm]	□ [mm]
WKL-000069	TA-1	Tapping Adapter 19 mm x M8	19	M8	8	6,2
WKL-000070	TA-1	Tapping Adapter 19 mm x M10	19	M10	10	8
WKL-000071	TA-1	Tapping Adapter 19 mm x M12	19	M12	9	7
WKL-000072	TA-2	Tapping Adapter 31 mm x M8	31	M8	8	6.2
WKL-000073	TA-2	Tapping Adapter 31 mm x M10	31	M10	10	8
WKL-000074	TA-2	Tapping Adapter 31 mm x M12	31	M12	9	7
WKL-000075	TA-2	Tapping Adapter 31 mm x M14	31	M14	11	9
WKL-000076	TA-2	Tapping Adapter 31 mm x M16	31	M16	12	9
WKL-000077	TA-2	Tapping Adapter 31 mm x M18	31	M18	14	11
WKL-000078	TA-2	Tapping Adapter 31 mm x M20	31	M20	16	12
WKL-000079	TA-3	Tapping Adapter 48 mm x M14	48	M14	11	9
WKL-000080	TA-3	Tapping Adapter 48 mm x M16	48	M16	12	9
WKL-000081	TA-3	Tapping Adapter 48 mm x M18	48	M18	14	11
WKL-000082	TA-3	Tapping Adapter 48 mm x M20	48	M20	16	12
WKL-000083	TA-3	Tapping Adapter 48 mm x M22/M24	48	M22, M24	18	14.5
WKL-000084	TA-3	Tapping Adapter 48 mm x M27	48	M27	20	16
WKL-000085	TA-3	Tapping Adapter 48 mm x M30	48	M30	22	18

## Blind hole tapping up to M30

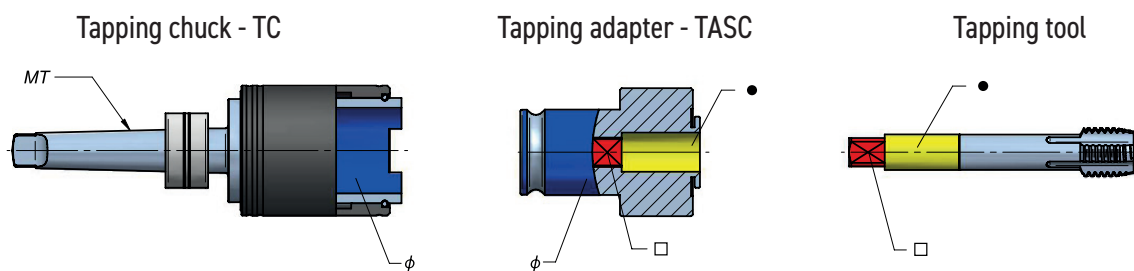

### TASC - Tapping Adapters Safety Clutch

Product Code	Type	Description	∅ [mm]	Tap size	● [mm]	□ [mm]
WKL-000095	TASC-1	Tapping Adapter with Safety Clutch 19 mm x M8	19	M8	8	6,2
WKL-000098	TASC-1	Tapping Adapter with Safety Clutch 19 mm x M10	19	M10	10	8
WKL-000099	TASC-1	Tapping Adapter with Safety Clutch 19 mm x M12	19	M12	9	7
WKL-000100	TASC-2	Tapping Adapter with Safety Clutch 31 mm x M8	31	M8	8	6.2
WKL-000101	TASC-2	Tapping Adapter with Safety Clutch 31 mm x M10	31	M10	10	8
WKL-000102	TASC-2	Tapping Adapter with Safety Clutch 31 mm x M12	31	M12	9	7
WKL-000103	TASC-2	Tapping Adapter with Safety Clutch 31 mm x M14	31	M14	11	9
WKL-000104	TASC-2	Tapping Adapter with Safety Clutch 31 mm x M16	31	M16	12	9
WKL-000105	TASC-2	Tapping Adapter with Safety Clutch 31 mm x M18	31	M18	14	11
WKL-000106	TASC-2	Tapping Adapter with Safety Clutch 31 mm x M20	31	M20	16	12
WKL-000107	TASC-3	Tapping Adapter with Safety Clutch 48 mm x M14	48	M14	11	9
WKL-000108	TASC-3	Tapping Adapter with Safety Clutch 48 mm x M16	48	M16	12	9
WKL-000109	TASC-3	Tapping Adapter with Safety Clutch 48 mm x M18	48	M18	14	11
WKL-000110	TASC-3	Tapping Adapter with Safety Clutch 48 mm x M20	48	M20	16	12
WKL-000111	TASC-3	Tapping Adapter with Safety Clutch 48 mm x M22/M24	48	M22, M24	18	14.5
WKL-000112	TASC-3	Tapping Adapter with Safety Clutch 48 mm x M27	48	M27	20	16
WKL-000113	TASC-3	Tapping Adapter with Safety Clutch 48 mm x M30	48	M30	22	18

■ **More optional accessories:**



Arbor MT3 x 32 mm Weldon for drilling diameter over 60 mm (2.3") up to 100 mm (4") depth  
Product code: UCW-0563-22-00-00-0



Arbor MT3 x 32 mm Weldon for drilling diameter over 60 mm (2.3") up to 50 mm (2") depth  
Product code: UCW-0739-04-00-00-0

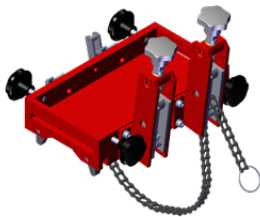

Pipe attachment DMP 501 for pipes with diameters of 150-500 mm (6-20")  
Product code: PDS-0111-03-00-01-0



Pressure cooling system capacity of 2 liters  
Product code: UKL-0440-16-00-00-0



PRO-122T SB TECHNICAL SPECIFICATION	
Motor Speeds (under load)	75–110 rpm (gear I) 135–200 rpm (gear II) 220–320 rpm (gear III) 390–570 rpm (gear IV)
Power	2300 W
Weight	28.5 kg (63 lbs)
Max milling capacity *	110 mm ÷ 120 mm for up to 2" D.O.C. cutters w/o swivel base in use 110 mm for up to 2" D.O.C. cutters with or w/o swivel base in use 100 mm for up to 4" D.O.C. cutters with or w/o swivel base in use
Max drilling capacity	31.75 mm (1-1/4")
Max Tap size	M30 (1-1/4")
Stroke	225 mm (9")
Max depth of cut	100 mm (4")
Voltage	1~ 220–240 V, 50–60 Hz 1~ 110–120 V, 50–60 Hz
Overload protection	yes
Overheat protection	yes
Continuous Speed Adjustment	yes
ESSS (Electronic Speed Stabilization System)	yes
Semi-automatic gib adjustment	yes
MFSC (Magnetic Field Shape Control)	yes
ESB – Energy Saving Base	yes
Magnet detachment safeguard	yes
Magnetic clamping force (surface with the thickness of 25 mm and roughness Ra = 1.25)	1835 kgf (18 000 N)
Magnet Base Dimensions	110 mm × 220 mm × 50 mm 4.3" × 8.7" × 2"
Base adjustment range	shift +10 mm (0.39")/-5 mm (0.20") turn ±15°
Min. Workpiece Thickness	10 mm (3/8")
Spindle	MT3
Tool holder	19 mm (3/4") or 32 mm (1-1/4") Weldon
Product Code 220–240 V, 50–60 Hz	WRT-0739-10-20-00-0
Product Code 110–120 V, 50–60 Hz	WRT-0739-10-10-00-0

\* If more than 60 mm (2.36"), use an MT3 arbor with 32 mm Weldon tool holder up to 100 mm (4") depth (UCW-0563-22-00-00-0) or MT3 arbor with 32 mm Weldon tool holder up to 50 mm (2") depth (UCW-0739-04-00-00-0)

### Standard shipping set:

- Drilling machine
- Metal box
- Handle (3 pcs)
- MT3 arbor with 19 mm (0.75") Weldon tool holder
- Safety strap
- Cooling system
- Protective spring for cooling hose
- MT3 drift
- 6 mm hex wrench
- 5 mm hex wrench with a handle
- 2.5 mm hex wrench
- 8 mm combination wrench
- Tool can
- Locking connector (only in 115 V version)
- Operator's Manual

### Dimensions:

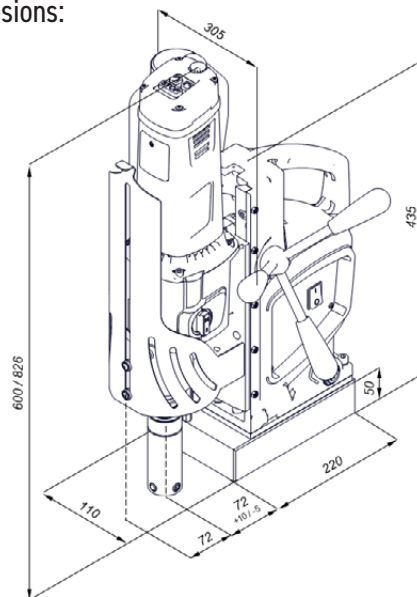

All information is subject to change without notice. 23.06



PROMOTECH Sp. z o.o.  
ul. Elewatorska 23/1, 15-620 BIAŁYSTOK, POLAND  
tel. (+48 85) 678 34 05, fax (+48 85) 662 78 77  
marketing@promotech.eu www.promotech.eu

Your local dealer:

