

## PRO-36 | COMPACTE MAGNEET BOORMACHINE



De meest compacte machine van Promotech, en een van de kleinste machines ter wereld. Superieure kenmerken van PRO-36 zijn onder meer:

- ultra licht gewicht
- versnellingsbak en geleider systeem uit één stuk
- speciaal ontworpen motor met heavy duty versnellingsbak
- onderhouds vriendelijk ontwerp
- onderhouds vrij geleider systeem

PRO-36 is uitgerust met de nieuwste generatie elektromagnetische basis met magnetisch veldvorm controlesysteem (MFSC) en magnetische adhesie controlemodule (MPAC), die de kleefkracht van de elektromagnetische basis detecteert en zowel de machine als de operator beschermt tegen te werken op een te dun werkstuk.





Max  
Ø 36 mm  
(1 7/16")



Max  
Ø 40 mm  
(1 9/16")



Max  
Ø 12 mm  
(1/2")

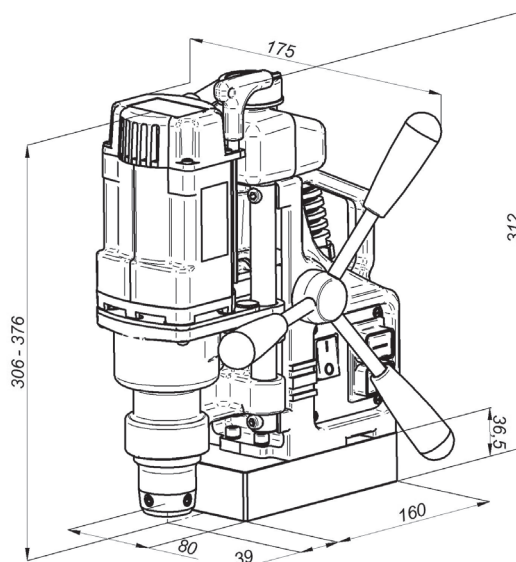

DMP 251 Pijpbevestiging hulpstuk



Koelsysteem 2 Liter



Vacuüm kleevoet



Perslucht ontluchting  
hulpstuk

#### PRO-36 TECHNISCHE SPECIFICATIES

Motor snelheid (onder belasting)	350 rpm
Vermogen	1020 W
Gewicht	10 kg
Kernboren maximaal	36 mm (1 7/16")
Spiraalboren maximaal	12 mm (1/2")
Verzinken maximaal	40 mm (1 9/16")
Slag	70 mm (2 3/4")
Maximale boor diepte	51 mm (2")
Voltage	1~ 220-240 V, 50-60 Hz 1~ 110-120 V, 50-60 Hz
MPAC (Magnetische Kleefkracht Controle)	yes
MFSC (Magnetische Veld Vorm Controle)	yes
Magnetische klemkracht (oppervlak met de dikte van 25 mm en ruwheid Ra = 1,25)	917 kgf (9000 N)
Afmetingen magneetvoet	80 x 161 x 36,5 [mm] 3-1/8 x 6-5/16 x 1-7/16 ["]
Minimale werkstuk dikte	6 mm (1/4")
Gereedschapshouder	19 mm (3/4") Weldon
Product Code 230V/50Hz	WRT-0440-10-20-00-4
Product Code 115V/60Hz	WRT-0440-10-10-00-4

#### ■ Standaard set:

- Magneet Boormachine
- Kunststof opberg koffer
- Veiligheids schild / Beschermplaat
- Koelvloeistof reservoir
- Veiligheids sjaorband
- Inbusleutel 4 mm
- Handleiding
- Standaard verzendgewicht - 16,7 kg (36 lbs)

#### ■ Geselecteerde extra accessoires:

- UKL-0440-16-00-00-0 Koelsysteem 2 Liter
- PDS-0587-00-00-00-0 Vacuüm kleevoet
- ZSP-0587-11-00-00-0 Perslucht ontluchting hulpstuk
- PDS-0110-03-00-01-0 Buisbevestiging DMP 251 voor buizen met een diameter van 80-250 mm (3-10")

