

## PRO-WP 150 PRO-WP 300

## SVEISEMANIPULATORER

Sveisemanipulatorer gjør det enkelt å rotere runde sveisegjenstander, gir bedre tilkomst til sveisesømmen, bidrar til å produsere sveiser av høy kvalitet og økte avsettmengder.

Frekvensomformer sikrer nøyaktig hastighetsjustering og hastighetsstabilisering ved innstilt verdi.

De reduserer tid og sparer på krefter til sveiserne, som nå kan fokusere på sveiseoppgaven uten å måtte forandre for mye på arbeidsstillingen sin.

Den kompakte designen tar minimalt med gulvplass og vipping opp til 90 grader forbedrer ergonomien til arbeidsområdet.

Utvalg av ulike hjelpetilbehør gjør det mulig å opprette en avansert modulær sveisestasjon som er skreddersydd til gitte sveise- eller skjæreapplikasjoner. Dette for å maksimere produksjonseffektiviteten.



### ■ Funksjoner og fordeler:

- Venstre eller høyre rotasjon
- Kontinuerlig hastighetsjustering
- Hastighetsstabilisering innenfor hele hastighetsområde fra 0,12 rpm til 2,4 rpm
- Start/stopp (både kontroller og fotpedal)
- Lysbuetenning
- Fjernkontroll
- Fotpedal for håndfri betjening (ekstrautstyr)
- Kraftig konstruksjon
- Massevis av ekstrautstyr gjør det mulig å bygge en modulær sveisestasjon skreddersydd for ulike sveise- og skjæreapplikasjoner

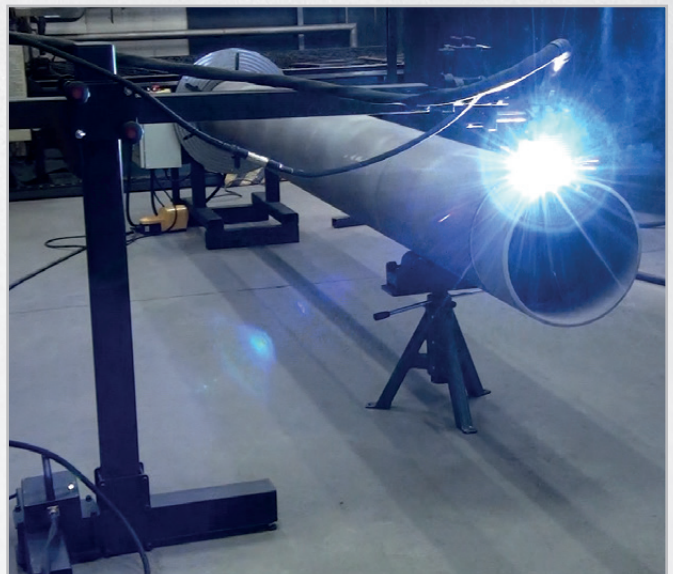

## ■ Valgfritt tilbehør for ulike sveise- og skjæreapplikasjoner:

- Dreiebenk selvsentrerende chuck D250



Utvendig klemdiameter:  $\Phi$  90–250 mm

Innvendig klemdiameter:  $\Phi$  6–110 mm,  
 $\Phi$  80–250 mm

Produktkode: UCW-0681-18-00-00-0

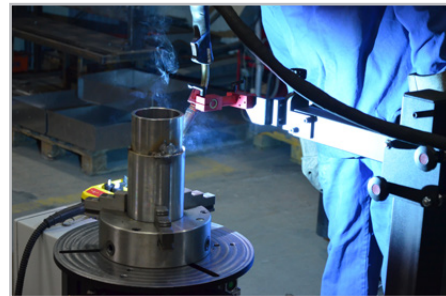
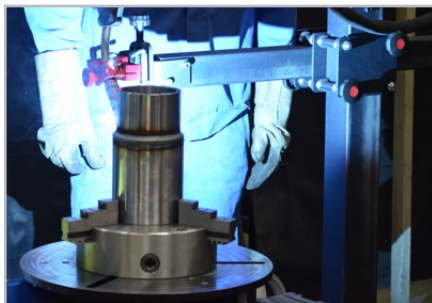

- Dreiebenk selvsentrerende chuck D400



Utvendig klemdiameter:  $\Phi$  120–400 mm

Innvendig klemdiameter:  $\Phi$  15–210 mm,  
 $\Phi$  120–400 mm

Produktkode: UCW-0681-17-00-00-0

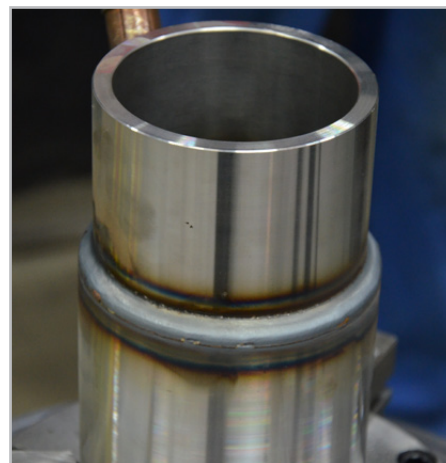
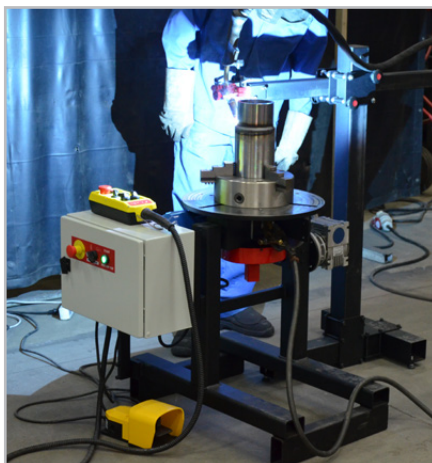

- Nøkkelløs selvsentrerende chuck DD300



Utvendig klemdiameter:  $\Phi$  170 – 280 mm

Innvendig klemdiameter:  $\Phi$  80 – 190 mm

Produktkode: UCW-0681-19-00-00-0

- Nøkkelløs selvsentrerende chuck DD400



Utvendig klemdiameter:  $\Phi$  250 – 380 mm

Innvendig klemdiameter:  $\Phi$  120 – 250 mm

Produktkode: UCW-0681-20-00-00-0

- Pistolholder



Festes direkte på sveisemanipulatoren  
Produktkode: UCW-0681-14-00-00-0



- MINI C&B type PRO-WA 1X1



Produktkode: STJ-0709-10-00-00-0



MINI C&B type PRO-WA 1X1	
Høyde	1160 mm
Lengde	1188 mm
Bredde	500 mm
Vertikal bevegelsesområde	810 mm
Horisontal bevegelsesområde	815 mm
Maksimal belastning med fullt utstrakt horisontal arm	7 kg

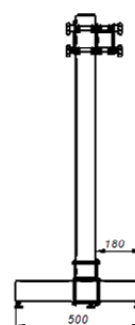
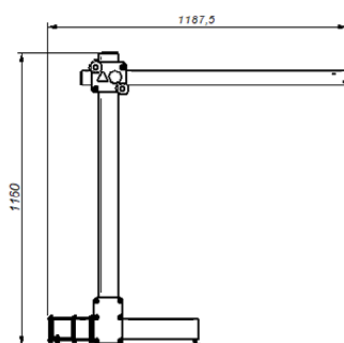

- Tverrsleide (ekstrautstyr)



35 mm x 35 mm (venstre og høyre, opp og ned)  
Produktkode: ZSP-0466-14-00-00-0



- Rullebukk



Lastekapasitet: 1000 kg (2200 lbs)  
Produktkode: WSP-0681-16-00-00-0



- Pendeloscillator OSC-8



Produktkode: OSC-0497-10-00-00



- Strømforsyning



Produktkoder:  
 ZSL-0497-16-00-00-0 (230 V CEE)  
 ZSL-0497-16-00-01-0 (115 V USA)  
 ZSL-0497-16-00-02-0 (230 V AU)  
 ZSL-0497-16-00-03-0 (230 V UK, type G)  
 ZSL-0497-16-00-04-0 (230 V IN, type D)

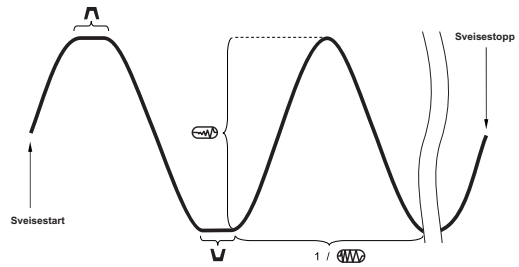

Parameter	Verdi	Beskrivelse
	0-100%	Oscillasjonsbredde
	0-100%	Oscillasjonshastighet
	0-3 s	Oscillasjonsoppholdstid i toppposisjon
	0-3 s	Oscillasjonsoppholdstid i bunnposisjon

OSC-8 PENDELVERK	
Spenning	14-24 V DC
Effekt	50 W
Pistoltype	MIG/MAG
Pistoldiameter	16-22 mm (5/8-7/8")
Oscillasjonstype	Pendling
Oscillasjonsbredde ved r=150 mm (6")	1-30 mm (1-100 %) 1/32-1-3/16" (1-100 %)
Oscillasjonshastighet ved oscillasjonsbredde på 10 mm (3/8") og null oppholdstid i ender	12-115 sykluser/min (1-100 %)
Oscillasjonsoppholdstid i ender	0-3 s
Maksimalt dreiemoment	8 N·m (5,7 lb·ft)
Nødvendig omgivelsestemperatur	0-50 °C (32-122 °F)
Vekt	2 kg (4 lbs)
Produktkode:	OSC-0497-10-00-00-0



## ■ Klemmetilbehør for sveisepistoler (å velge mellom)



- Kort stang pistolholder med klemme 16-22 mm  
Produktkode: UCW-0476-20-00-00-0



- Lang stang pistolholder med klemme 16-22 mm  
Produktkode: UCW-0466-04-00-00-0



- Kort, lav stang pistolholder med klips 16-22 mm  
Produktkode: UCW-0476-06-00-00-0



- Kort stang pistolholder med klips 16-22 mm  
Produktkode: UCW-0476-27-00-00-0



- Lang stang pistolholder med klips 16-22 mm  
Produktkode: UCW-0466-22-00-00-0

## ■ Klemmetilbehør for skjærebrennere (å velge mellom)



- Standard brennerholder med klemme 28-35 mm og grov vinkeljustering  
Produktkode: UCW-0475-28-00-00-0



- Nøyaktig brennerholder med klemme 28-35 mm og presis vinkeljustering  
Produktkode: UCW-0475-08-00-00-0



- Standard maskinbrennerholder for gasskjæring i vertikal posisjon og grov vinkeljustering  
Produktkode for holder til 30 mm maskinbrenner med tangstang: UCW-0475-61-00-00-0  
Produktkode for holder til 35 mm maskinbrenner med tangstang: UCW-0475-29-00-00-1



- Nøyaktig maskinbrennerholder for gasskjæring i vertikal posisjon og presis vinkeljustering.  
Produktkode for holder til 30 mm maskinbrenner med tangstang: UCW-0475-59-00-00-0  
Produktkode for holder til 35 mm maskinbrenner med tangstang: UCW-0475-42-00-00-1



- Stang 150 mm for skjærebrennerholdere  
Produktkode: SLP-0233-13-02-00-1

• Klemmesett

Produktkode: ZST-0681-15-00-00



Klemme 100 mm x 32 mm x 19 mm  
(3 stk)



Dobbel endebolt 75 mm x 30 mm (4 stk)  
Dobbel endebolt 100 mm x 30 mm (4 stk)  
Dobbel endebolt 125 mm x 30 mm (4 stk)  
Dobbel endebolt 150 mm x 30 mm (4 stk)  
Dobbel endebolt 175 mm x 30 mm (4 stk)  
Dobbel endebolt 200 mm x 30 mm (4 stk)



Klemme 150 mm x 32 mm x 22 mm  
(3 stk)



Bakke 28 mm x 20 mm - 38 mm  
(4 stk)



Bakke 35 mm x 28 mm - 64 mm  
(4 stk)



Bakke 98 mm x 64 mm - 152 mm  
(4 stk)



Flensmutter  
M10 x 15 mm  
(6 stk)



Forlengelsesmutter  
M10 x 30 mm lang  
(4 stk)

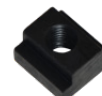

T-spormutter  
12 mm x 18 mm x 14 mm  
(6 stk)



Lysbuetenningen gjør at  
sveiseprosessen kan startes  
og stoppes eksternt.

Teknisk spesifikasjon	PRO-WP 150	PRO-WP 300
Spenning	1~ 220-240 V, 50-60 Hz 1~ 100-120 V, 50-60 Hz	1~ 220-240 V, 50-60 Hz 1~ 100-120 V, 50-60 Hz
Effekt	0,25 kW	0,25 kW
Rotasjonshastighet min/maks	0,12 - 2,4 rpm	0,12 - 2,4 rpm
Maks lastekapasitet	150 kg (331 lbs)	300 kg (661 lbs)
Senterforskyvning fra bordet ved 90° tilt	up to 100 mm	up to 100 mm
Diameter på frontplaten	450 mm (17.7")	630 mm (24.8")
Hulaksel innvendig diameter	28 mm (1.1")	28 mm (1.1")
Vippeområde med trinnløs vinkeljustering	0-90°	0-90°
Vippefunksjon	manual	manual
Maks. sveisestrømoverføring	400 A	400 A
Vekt	115 kg (254 lbs)	150 kg (330 lbs)
Produktkode:	PZY-0681-10-10-00-0	PZY-0682-10-10-00-0

Dimensjoner:

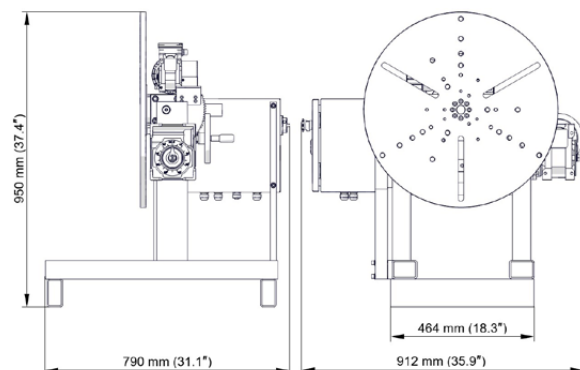
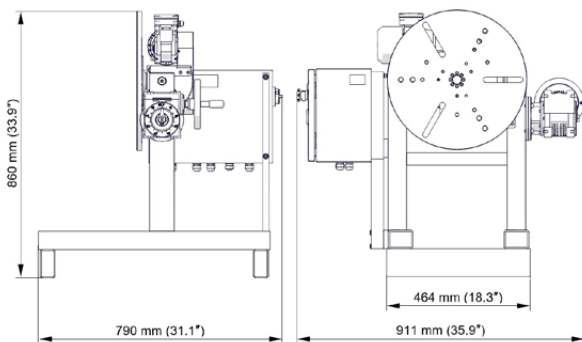

**American Welding Society**  
Supporting Company Member

Mitglied im DVS - Deutscher Verband für  
Schweißen und verwandte Verfahren e. V.



All informasjon kan endres uten forvarsel. 22.08



PROMOTECH Sp. z o.o.  
ul. Elewatorska 23/1, 15-620 BIAŁYSTOK, POLAND  
tel. (+48 85) 678 34 05, fax (+48 85) 662 78 77  
marketing@promotech.eu www.promotech.eu

Din lokale forhandler:

