

## PRO-60 HP PRO-110 HP

## DRAAGBARE HYDRAULISCHE PONSMACHINE



### Voornaamste kenmerken en voordelen:

- Dubbele actie - volledig geautomatiseerd proces van pons en retour beweging
- Breed scala aan pons diameters tot 27 mm
- Moderne constructie
- intelligent besturingssysteem met afstelling en automatische materiaal herkenning
- Modus-indicatielampje
- Bescherming tegen onbedoeld in schakelen
- Gemakkelijk te hanteren in niet-normale posities
- alle aansluit punten aan de achterzijde
- Breed scala aan speciaal gevormde ponsen en matrijzen
- Gepatenteerd compact beweegbaar hydraulisch persstation
- Uniek hydraulisch persstation verhoogt zowel de productiviteit als het comfort van de operator

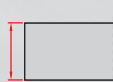

Maximale  
materiaal dikte



Max. Hoogte  
(nek lengte)



Max. gat  
afmeting



max. afmeting  
ovaal gat



Pons tijd



Pons kracht



dubbelwerkende  
hydraulische beweging

PRO-60 HP

13 mm

60 mm

27 mm

25 x 18 mm

5 sec

35 ton

JA

PRO-110 HP

16 mm

110 mm

27 mm

25 x 18 mm

8 sec

47 ton

JA

Draagbare Hydraulische Ponsmachine Technische specificaties	Model PRO-60 HP	Model PRO-110 HP
Max. Hoogte (nek lengte)	60 mm	110 mm
Max. gat afmeting	Ø 27 mm	Ø 27 mm
max. afmeting ovaal gat	25 x 18 mm	25 x 18 mm
Pons tijd	5 sec	8 sec
Max. werkstuk dikte	13 mm	16 mm
Pons kracht	35 ton	47 ton
Werk druk	700 bar	700 bar
Gewicht	20 kg	35 kg
Product code	GLW-0522-10-00-00-1	GLW-0507-10-00-00-0

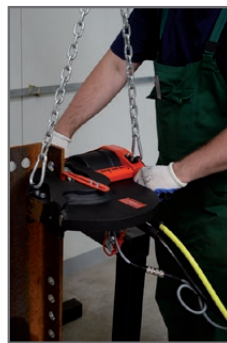

Kan zowel in verticale als horizontale positie werken

Dubbelwerkend hydraulisch persstation model HPP 700 / 1.5	
Stroomvoorziening*	230V/50Hz; 115V/60Hz
Vermogen	2000 W
Werk druk	700 bar
Pompvermogen	1.5 L/min
Olie capaciteit	10 L
Product code	ZSL-0517-10-20-00-0 HPP-700/1,5 / 220-240V/50Hz

\* Neem contact op met Promotech voor andere netspanningsopties



Draagbaar hydraulisch persstation met legbord voor het transport van de ponsmachine



Afmetingen:

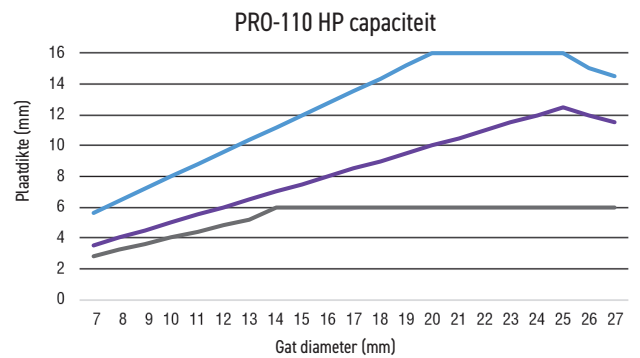
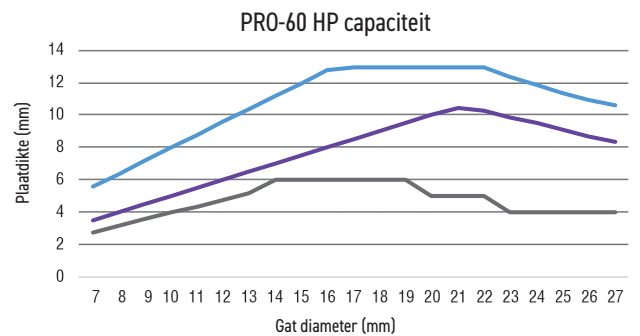
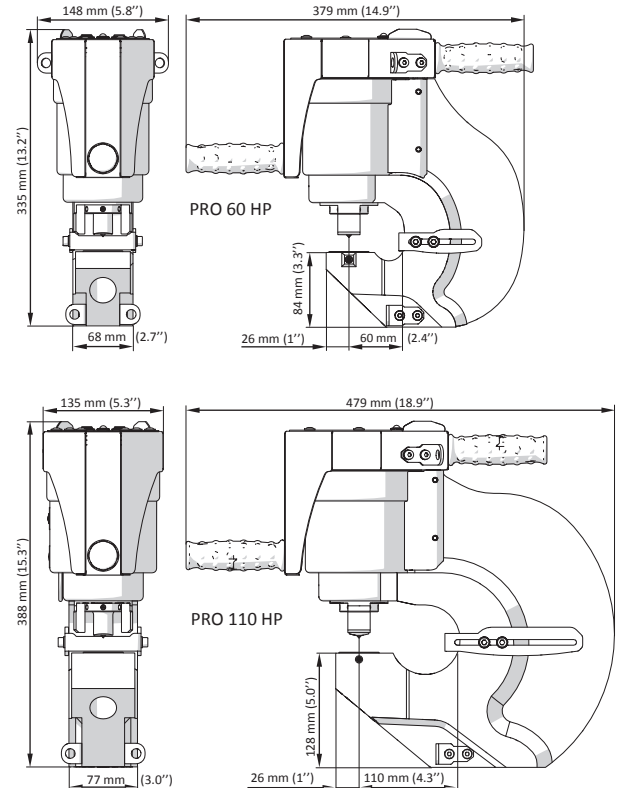

— Rm < 490 MPa — Rm = 490-630 MPa — Rm = 630-750 MPa



Veerbalancer voor de PRO-60 HP; Product code: BLN-000004  
 Veerbalancer voor de PRO-110 HP; Product code: BLN-000005

Personaliseer uw werkplek met een scala aan optionele accessoires.

### Takel set

Product code: ZUR-0517-15-00-00-0



Eenvoudige installatie en gemakkelijke aanpassing van hoogte en balansregeling.

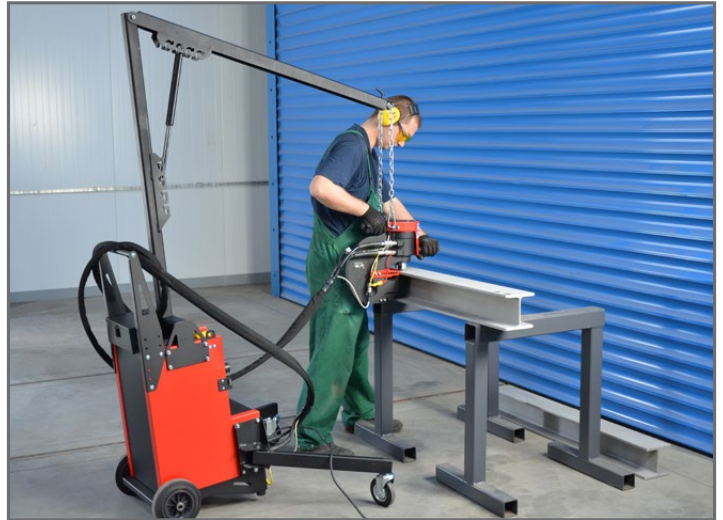

Hijns arm en 2 steunen met wielen zorgen voor eenvoudig gebruik van ponsmachine- en hydraulisch persstation als één geheel.

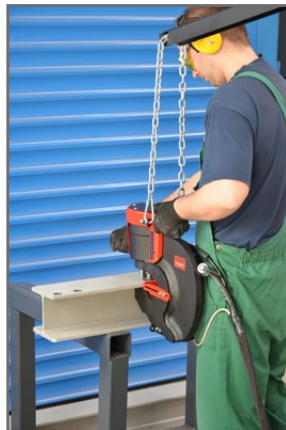

Unieke oplossing die uw werk zo efficiënt en comfortabel maakt als nooit tevoren.

### Geleider wiel slede

Product code: PRW-0507-90-00-00-0

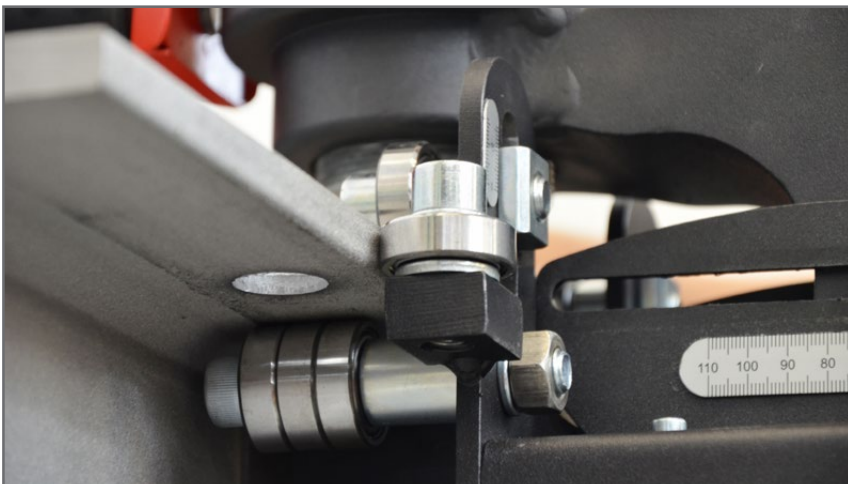

Maakt een gemakkelijke en efficiënte beweging langs het werkstuk mogelijk.

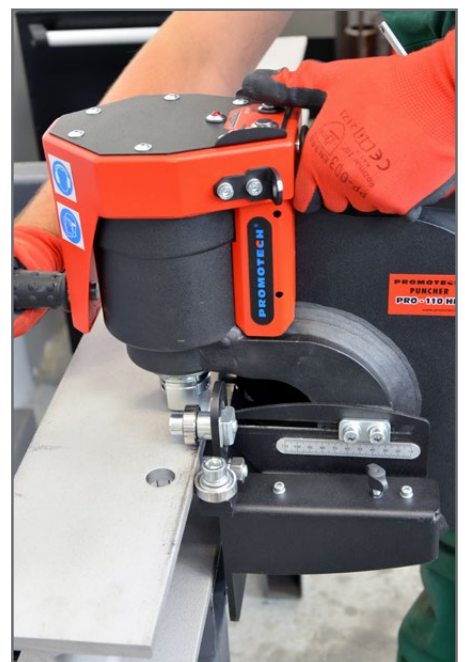

## Tafelstandaard met voetschakelaar

Product code: ZST-0507-91-00-00-0



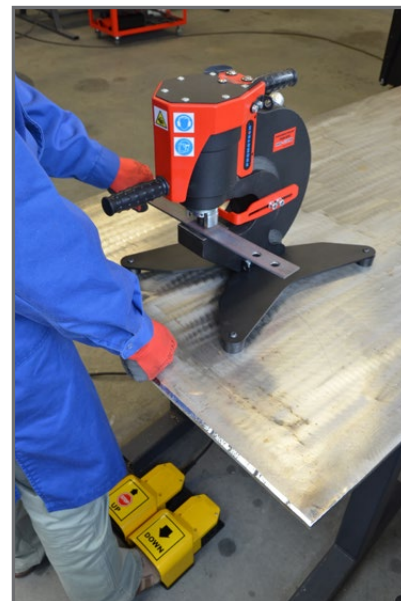

Er is geen veerbalancer of hijs arm nodig om de ponsmachine op zijn plaats te houden. De operator kan voetschakelaar gebruiken.





Voetschakelaar maakt handsfree machinebesturing op tafelconfiguratie mogelijk

## Ponsen en Matrijzen

Hydraulisch Pons gereedschap		
Langwerpig [mm]	Pons - product code	Matrijs - product code
16x8	STM-0507-30-13-00-0	MTY-0507-70-13-00-0
18x9	STM-0507-30-12-00-0	MTY-0507-70-12-00-0
18x11	STM-0507-30-11-00-0	MTY-0507-70-11-00-0
20x10	STM-0507-30-10-00-0	MTY-0507-70-10-00-0
20x12	STM-0507-30-09-00-0	MTY-0507-70-09-00-0
20x14	STM-0507-30-08-00-0	MTY-0507-70-08-00-0
22x11	STM-0507-30-07-00-0	MTY-0507-70-07-00-0
22x14	STM-0507-30-06-00-0	MTY-0507-70-06-00-0
24x12	STM-0507-30-05-00-0	MTY-0507-70-05-00-0
25x9	STM-0507-30-04-00-0	MTY-0507-70-04-00-0
25x12	STM-0507-30-03-00-0	MTY-0507-70-03-00-0
25x13	STM-0507-30-02-00-0	MTY-0507-70-02-00-0
25x14	STM-0507-30-01-00-0	MTY-0507-70-01-00-0
25x16	STM-0507-30-17-00-0	MTY-0507-70-17-00-0
25x18	STM-0507-30-00-00-0	MTY-0507-70-00-00-0

Diverse hydraulische ponsgereedschappen zijn op aanvraag verkrijgbaar in imperiale of metrische maten.

Hydraulisch Pons gereedschap			
Diameter [mm]	Pons - product code	Matrijs - product code	Matrijs 5° - product code
7	STM-0507-20-18-00-0	MTY-0507-40-18-00-0	-
8	STM-0507-20-17-00-0	MTY-0507-40-17-00-0	-
9	STM-0507-20-16-00-0	MTY-0507-40-16-00-0	MTY-0507-50-16-00-0
10	STM-0507-20-15-00-0	MTY-0507-40-15-00-0	MTY-0507-50-15-00-0
11	STM-0507-20-14-00-0	MTY-0507-40-14-00-0	MTY-0507-50-14-00-0
12	STM-0507-20-13-00-0	MTY-0507-40-13-00-0	MTY-0507-50-13-00-0
13	STM-0507-20-12-00-0	MTY-0507-40-12-00-0	MTY-0507-50-12-00-0
14	STM-0507-20-11-00-0	MTY-0507-40-11-00-0	MTY-0507-50-11-00-0
15	STM-0507-20-10-00-0	MTY-0507-40-10-00-0	MTY-0507-50-10-00-0
16	STM-0507-20-09-00-0	MTY-0507-40-09-00-0	MTY-0507-50-09-00-0
17	STM-0507-20-08-00-0	MTY-0507-40-08-00-0	MTY-0507-50-08-00-0
18	STM-0507-20-07-00-0	MTY-0507-40-07-00-0	MTY-0507-50-07-00-0
19	STM-0507-20-06-00-0	MTY-0507-40-06-00-0	MTY-0507-50-06-00-0
20	STM-0507-20-05-00-0	MTY-0507-40-05-00-0	MTY-0507-50-05-00-0
21	STM-0507-20-04-00-0	MTY-0507-40-04-00-0	MTY-0507-50-04-00-0
22	STM-0507-20-03-00-0	MTY-0507-40-03-00-0	MTY-0507-50-03-00-0
23	STM-0507-20-02-00-0	MTY-0507-40-02-00-0	MTY-0507-50-02-00-0
24	STM-0507-20-01-00-0	MTY-0507-40-01-00-0	MTY-0507-50-01-00-0
25	STM-0507-20-00-00-0	MTY-0507-40-00-00-0	MTY-0507-50-00-00-0
26	STM-0507-20-19-00-0	MTY-0507-40-19-00-0	MTY-0507-50-19-00-0
27	STM-0507-20-20-00-0	MTY-0507-40-20-00-0	MTY-0507-50-20-00-0

Alle informatie kan zonder voorafgaande kennisgeving worden gewijzigd. 21.12



PROMOTECH Sp. z o.o.  
ul. Elewatorska 23/1, 15-620 BIAŁYSTOK, POLAND  
tel. (+48 85) 678 34 05, fax (+48 85) 662 78 77  
marketing@promotech.eu www.promotech.eu

Uw lokale dealer

