

■ PRO-36 | DRILLS FOR SPECIAL APPLICATIONS



■ PRO-36 MS

The machine with swivel magnetic base is dedicated to operate with convex (min diameter - 300 mm) and concave (min diameter 1000 mm) materials. Four individual swivel magnets adjust to the surface of detail so the machine does not require perfectly flat material do operate. Additionally every magnet is equipped with variable holding force feature. This allows easy machine positioning while magnets are partially engaged. The magnetic base does not require electricity thus assures more safety in power loss situation.

■ PRO-36 PM

The machine with magnetic base is dedicated to operate with the risk of power loss applications (e.g. drilling in the wall). The magnetic base is equipped with very strong neodymium magnets and does not require electricity to operate. Switchable holding force feature enables easy and precise positioning of the drill, while magnetic base is partially engaged.



■ PRO-36 T3

The machine with electromagnetic base is dedicated to operate with steel profiles. Minimum thickness of the wall can be as thin as 3 mm. Unique design allows optimal magnetic field distribution so the holding force is comparable to the regular base placed on material which is twice as thick. It makes it suitable to work on really thin materials.



TECHNICAL SPECIFICATIONS	PRO-36 MS	PRO-36 PM	PRO-36 T3
Motor speed (under load)	350 rpm	350 rpm	350 rpm
Power	1020 W	1020 W	1020 W
Weight	14 kg (31 lbs)	13 kg (29 lbs)	11 kg (24 lbs)
Max milling capacity	36 mm (1 7/16")	36 mm (1 7/16")	36 mm (1 7/16")
Max countersinking	40 mm (1 9/16")	40 mm (1 9/16")	40 mm (1 9/16")
Stroke	70 mm (2 3/4")	70 mm (2 3/4")	70 mm (2 3/4")
Max depth of cut	35 mm (1 3/8")	45 mm (1 3/4")	51 mm (2")
Voltage	1~ 110-120 V, 50-60 Hz 1~ 220-240 V, 50-60 Hz	1~ 110-120 V, 50-60 Hz 1~ 220-240 V, 50-60 Hz	1~ 110-120 V, 50-60 Hz 1~ 220-240 V, 50-60 Hz
MFSC (Magnetic Field Shape Control)	-	-	yes
Magnetic base holding force	612 kgf (6 000 N)	612 kgf (6 000 N)	918 kgf (9 000 N)
Magnetic base dimensions	243mm × 218 mm × 96 mm 9.57" × 8.58" × 3.78"	98 mm × 237 mm × 100 mm 3.86" × 9.33" × 3.87"	100 mm × 200 mm × 38 mm 3.94" × 7.87" × 1.5"
Minimum workpiece thickness	5 mm (0.24")	5 mm (0.24")	3 mm (0.12") for rigid steel profiles 3 - 6 mm (0.12" - 0.24") to be careful
Tool holder	19 mm (3/4") Weldon	19 mm (3/4") Weldon	19 mm (3/4") Weldon
Product Code (110-120V)	WRT-0440-10-10-05-4	WRT-0440-10-10-06-4	WRT-0440-10-10-04-4
Product Code (220-240V)	WRT-0440-10-20-05-4	WRT-0440-10-20-06-4	WRT-0440-10-20-04-4

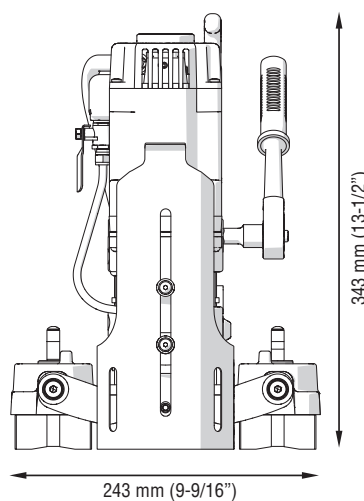
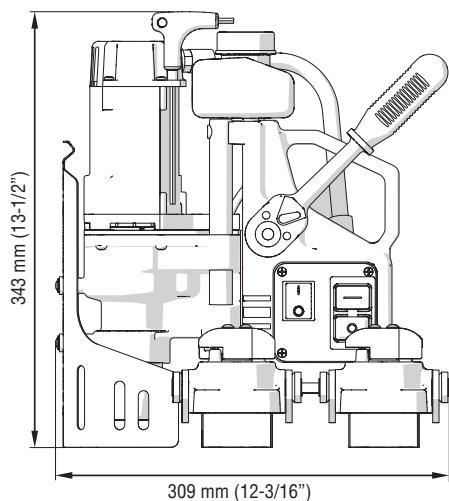
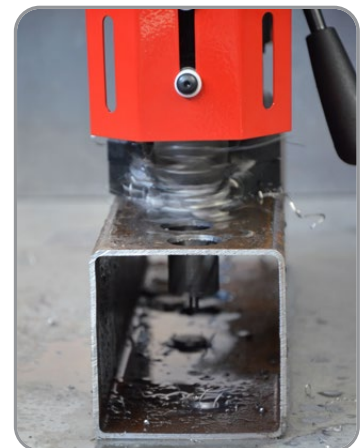
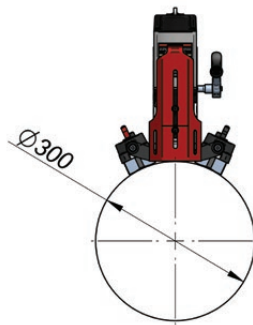
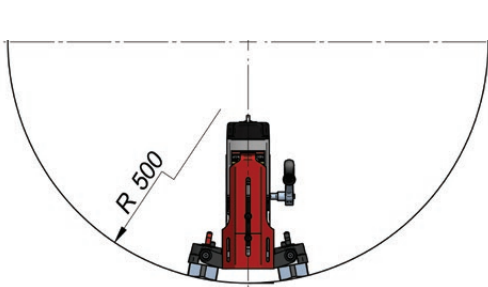

All information is subject to change without notice. 21.12



PROMOTECH Sp. z o.o.
ul. Elewatorska 23/1, 15-620 BIAŁYSTOK, POLAND
tel. (+48 85) 678 34 05, fax (+48 85) 662 78 77
marketing@promotech.eu www.promotech.eu

Your local dealer:

