

TFP1

NEW GRIND

Permanent-electro magnetic system with fine pole pitch for high precision grinders

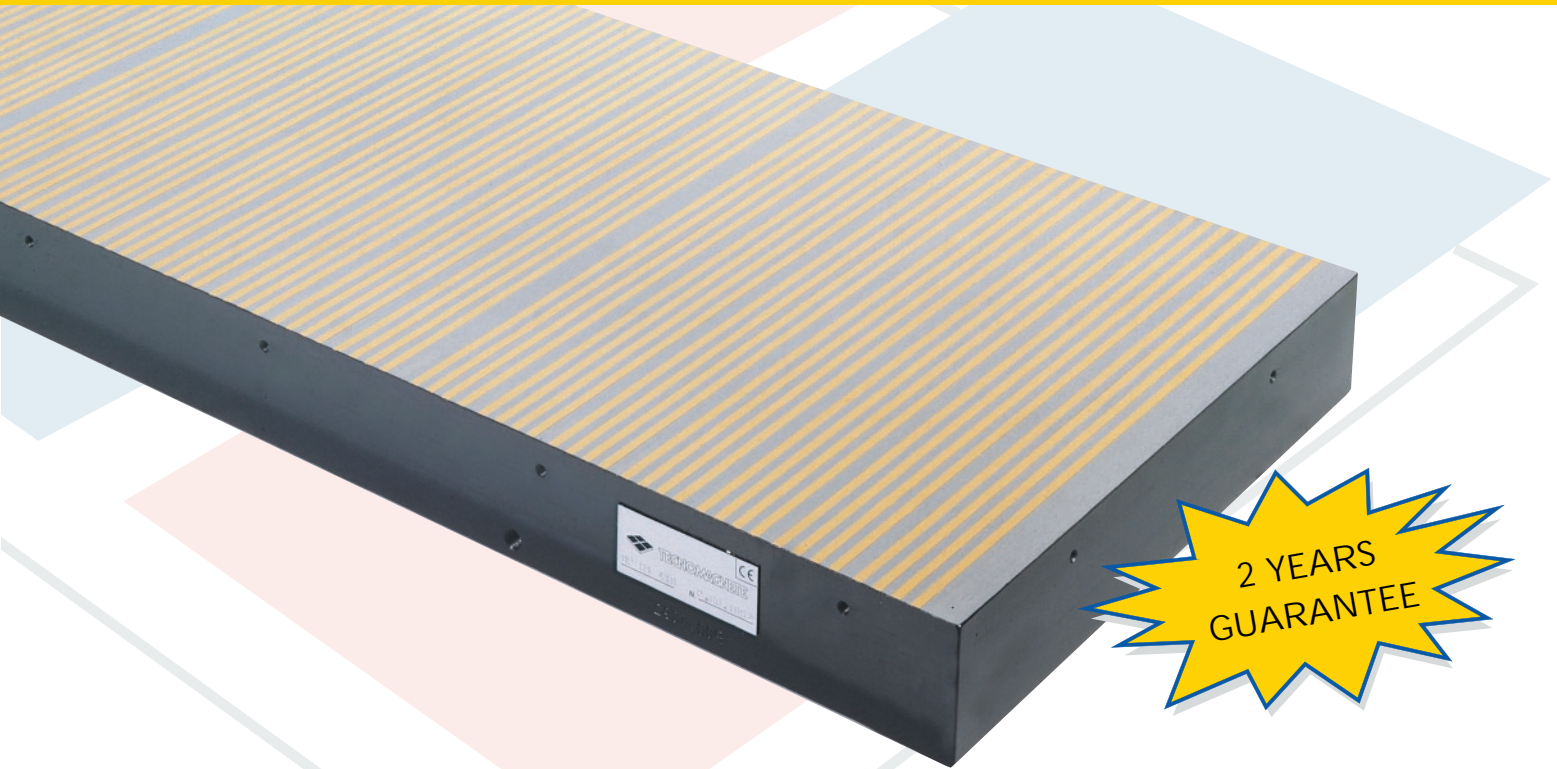

THE POWER OF EXPERIENCE

25 years of continuous improvements, a constant cooperation with the most important machine manufacturers and the guarantee of the worldwide leader Company in the magnetic workholding field are the TFP1 series background. Tecnomagnete permanent-electro chucks offer power and flexibility, adapt to any type of grinding machine.

HIGH DENSITY POLARITY

The transversal fine pole pitch allows multiple and close magnetic paths with a very reduced flux short circuiting depth (5 mm), thus being able to generate a safe holding power for thin and small work pieces as well as for larger parts.

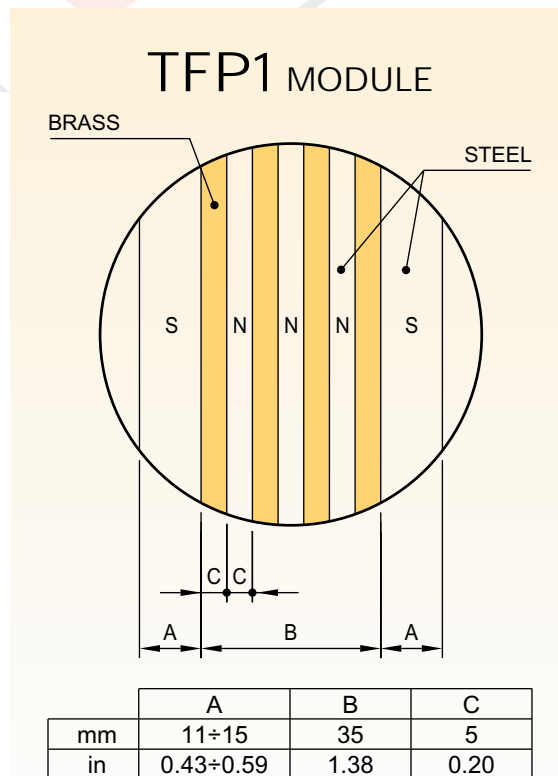

TOTALLY METALLIC AND ACTIVE SURFACE

The steel-brass combination on the whole surface assures excellent stability over time and a better possibility for high tolerances. The totally active surface maximizes the performance of the machine. Since it is possible to position the parts freely without stops and a larger production rate will be achieved.

SAFE FORCE

The TECNOMAGNETE permanent-electro patented circuit allows to activate-deactivate the chuck with short impulses for the duration of a few seconds. During the clamping phase the electric power is excluded, allowing to obtain the highest level of safety. Besides the energy saving the chuck will maintain a cold condition with the related absence of dilatations or deformations.

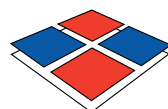

TECNOMAGNETE

Safety through power

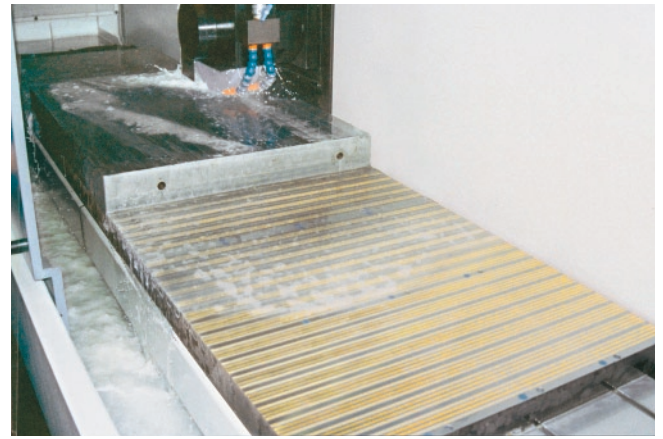
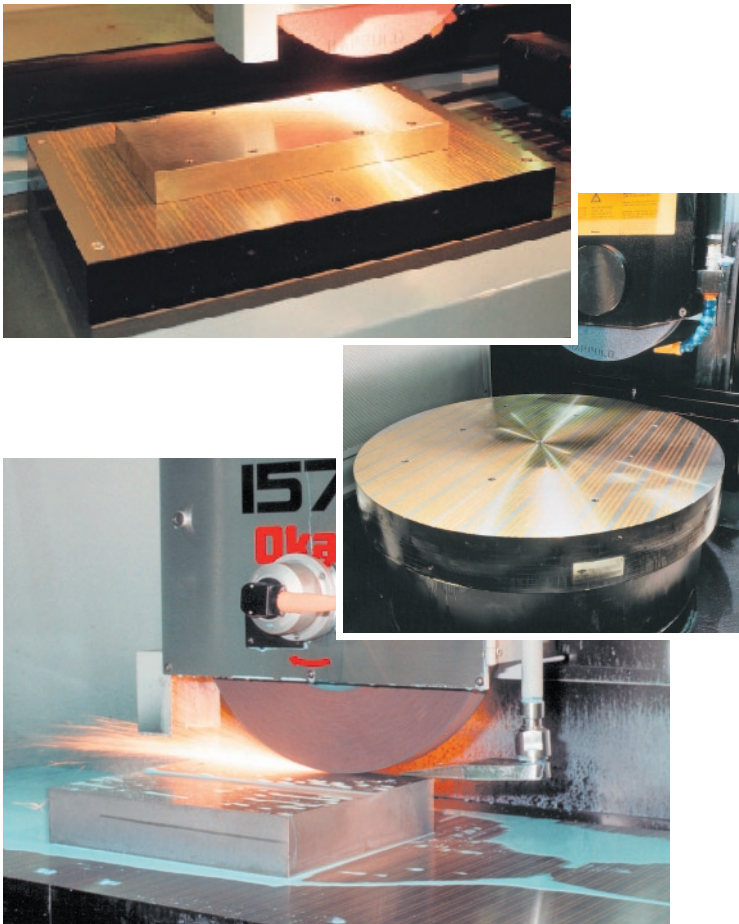

THROUGH FIXING HOLES

Through holes can be executed on the indirect poles in order to match with the "T" slots of the machine table and to guarantee a perfect planarity by and an easy installation.

Multiple chucks can be coupled to compose large magnetic tables.

MONOBLOCK STRUCTURE

The basic frame of the TFP chucks is machined from a solid block of steel, allowing unique rigidity and absolute stability over the time.



ELECTRONIC CONTROL

The electronic control units are available in two versions:

ST100R

For single chuck activation
- 3 levels power regulator

ST200R

Channels selection
- 8 levels power regulator
- Remote control

DIGITAL REMOTE CONTROL

Its functions, managed by a digital microprocessor, allows the control of the chuck from a distance such as:

- Magnetizing and demagnetizing cycles (1-2) sec.
- Adjustment of the anchoring power on 8 easily repeatable, pre-selectable levels.

NUFLUX SYSTEM

The control units are standard equipped with the patented "NUFLUX" system, which allow to totally and automatically eliminate, during the demagnetization phase, any possible magnetic residual from the surface of the part, with also alloyed materials.

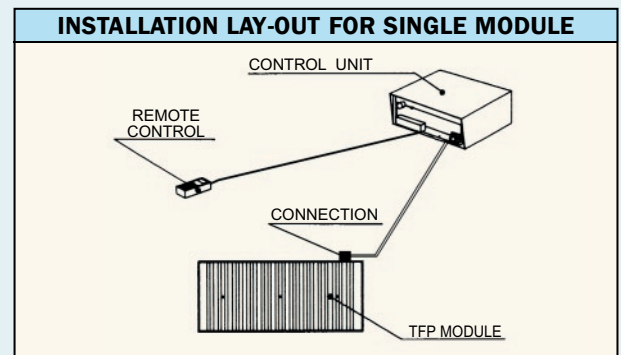

Standard Dimensions (nominal)

Mod. TFP1/R	A		B		Weight~	
	mm	in	mm	in	kg	lb
204	200	7.87	400	15.75	40	87
205	200	7.87	500	19.69	49	109
206	200	7.87	600	23.62	59	131
305	300	11.81	500	19.69	74	164
306	300	11.81	600	23.62	89	196
308	300	11.81	800	31.50	119	262
310	300	11.81	1000	39.37	148	327
406	400	15.75	600	23.62	119	262
407	400	15.75	700	27.56	138	305
408	400	15.75	800	31.50	158	349
410	400	15.75	1000	39.37	198	436
412	400	15.75	1200	47.24	237	523
508	500	19.69	800	31.50	198	436
510	500	19.69	1000	39.37	247	545
610	600	23.62	1000	39.37	297	654

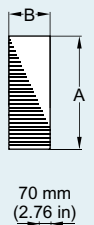

Mod. TFP1/C	D		Weight~	
	mm	in	kg	lb
0400	400	15.75	35	78
0500	500	19.69	55	122
0600	600	23.62	80	176
0700	700	27.56	109	240
0800	800	31.50	142	313
1000	1000	39.37	222	489

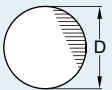

- a) The length of the standard connecting cables is 6 m
b) Fixing trough holes on request: "T" slot distance to be specified with the order

All data are drawn and checked with maximum care. We do not charge any responsibility for possible mistakes or omissions. We reserve the right to bring up any modification connected with the technological development.

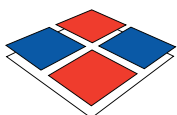

Headquarters

Safety through power
TECNOMAGNETE®

TECNOMAGNETE S.p.A.
Via Nerviano, 31 - 20020 Lainate (MI) - ITALY
Tel. +39+02.937.591 - Fax +39+02.935.708.57
<http://www.tecnomagnete.com>

Subsidiaries abroad:

TECNOMAGNETE S.A.R.L. - France
TECNOMAGNETE Inc. - U.S.A.
TECNOMAGNETE GmbH - Germany
TECNOMAGNETE Ltd. - U.K.
TECNOMAGNETE AB - Sweden

PROMOTECH Sp. z o.o.

ul. Elewatorska 23/1, 15-620 BIAŁYSTOK, POLAND
tel. (+48 85) 678-34-26, fax (+48 85) 662-78-77
e-mail: marketing@promotech.eu www.promotech.eu

rev. 06/2001-U.K.