

# MDS

## Permanent-electro magnetic modules for EDM die sinking

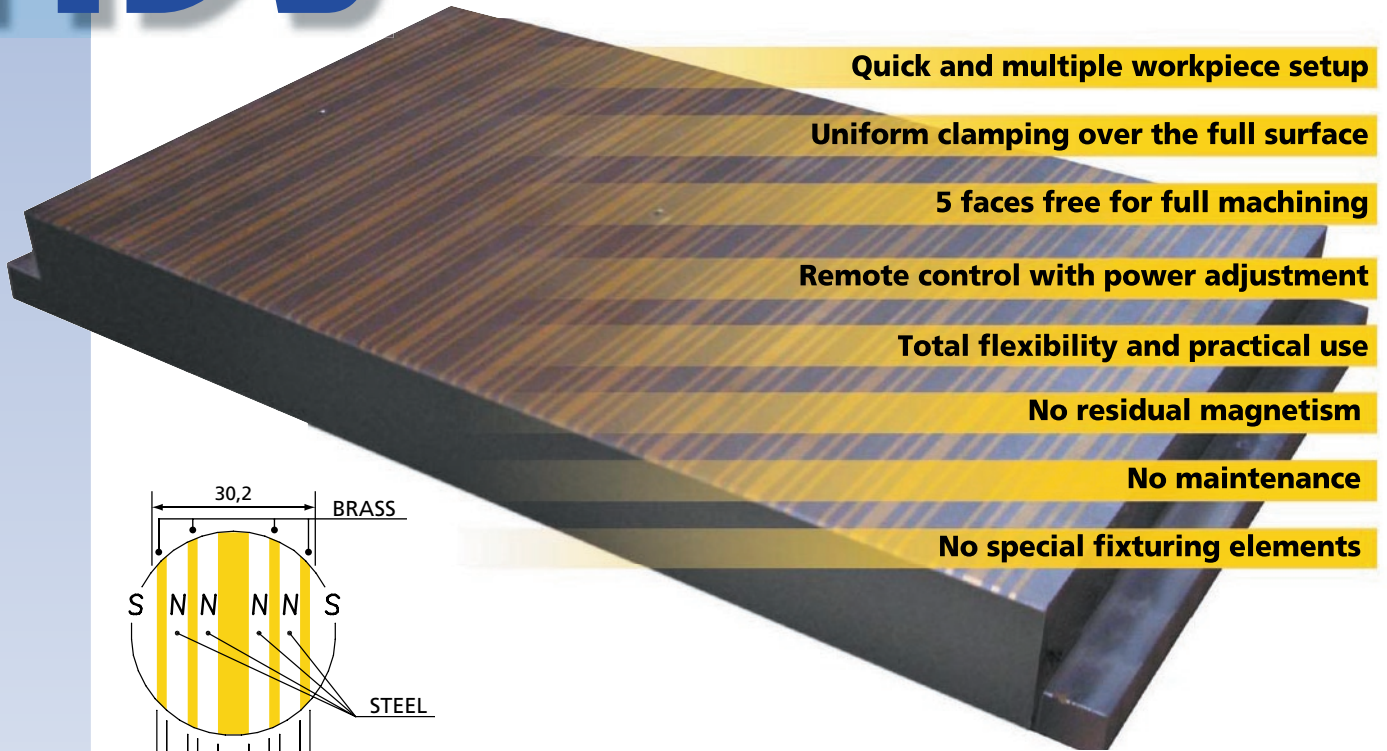

Quick and multiple workpiece setup

Uniform clamping over the full surface

5 faces free for full machining

Remote control with power adjustment

Total flexibility and practical use

No residual magnetism

No maintenance

No special fixturing elements

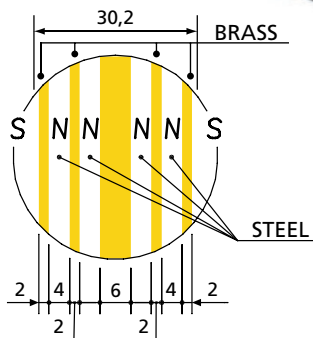

The fine pole pitch grants extremely tight magnetic closing (approximately 5mm) that allow the maximum clamping force even on small thickness pieces.

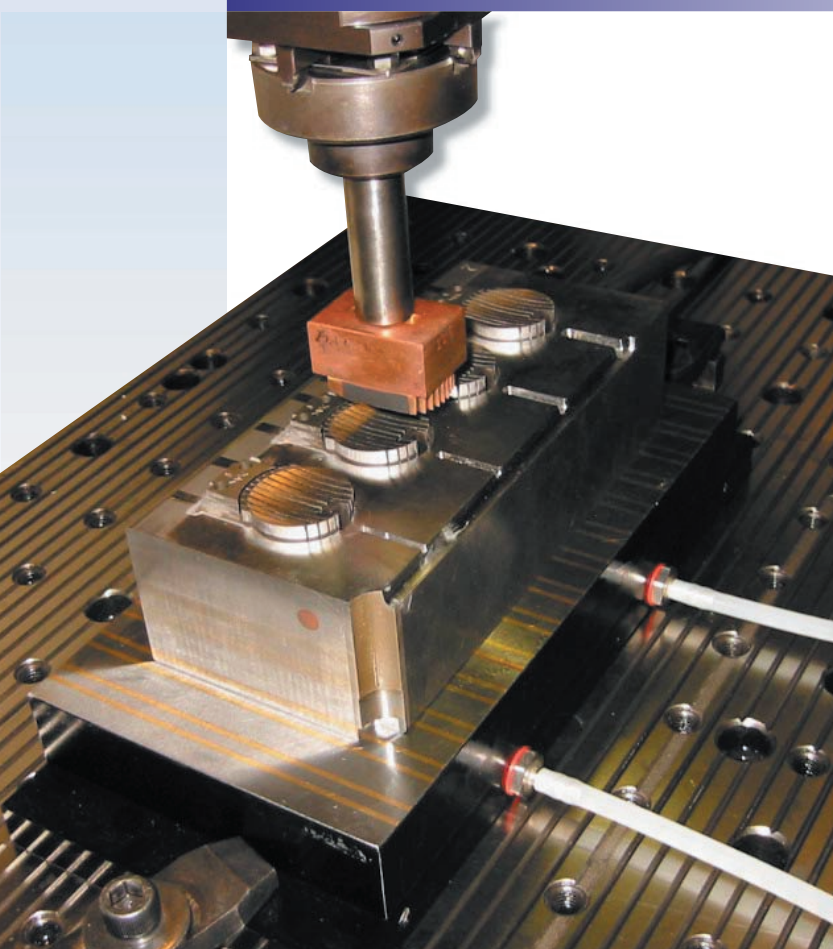

### INNOVATIVE TECHNOLOGY

A Tecnomagnete permanent-electro magnetic system is never affected by power outages since the electrical power is needed only to activate and de-activate the system. During the machining operation the workpiece remains clamped at indefinite period of time only by the strength of the high energy permanent magnets without any need of power feeding.

### GREAT ADVANTAGES

- Total safety
- Energy savings
- Quick return of the investment
- Cost effectiveness
- Easy installation
- High stability and rigidity
- Eco-compatibility



**TECNOMAGNETE®**  
Safety through power

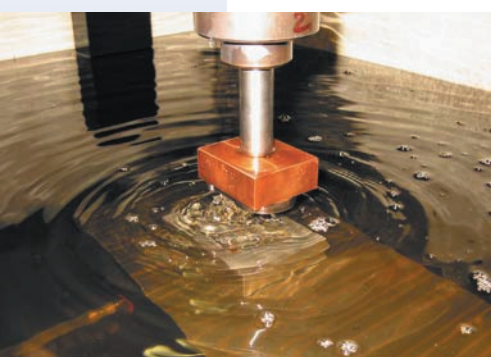
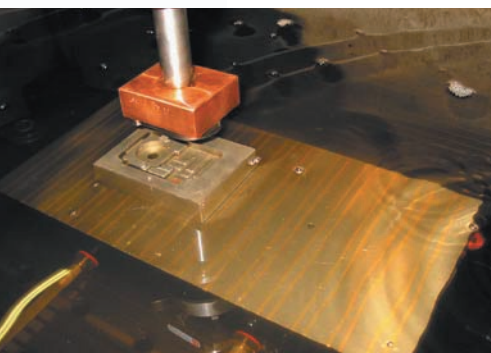

## FLUSHING HOLES

MDS chucks have as standard equipment a special washing circuit made by means of feed channels machined in the interior of the direct poles to allow 2 or 3 outlet holes, depending on chuck size, on the magnetic top. The feed connection is provided by 1/4" GAS threading.

## NUFLUX SYSTEM

The control units are standard equipped with the patented "Nuflux" system to eliminate automatically and totally, during the demagnetisation cycle, any residual magnetism from the workpiece even with highly alloy material.

## PERFECT FLUIDPROOFING

The electric circuit inside the chuck and the associated external electrical connections are protected by a special epoxy resin ensuring perfect sealing even with total immersion in the dielectric fluid.

## METALLIC SURFACE

The combination of steel and brass over the total surface ensure complete freedom from expansion or deformation and hence maximum precision and stability for any kind of machining.

## MONOLITHIC CONSTRUCTION

The bearing frame is machined from a solid steel plate to assure absolutely perfect structural rigidity.

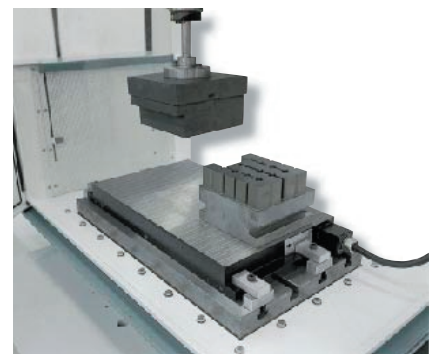

## THE ELECTRONIC CONTROL UNITS ARE AVAILABLE IN 2 VERSIONS

### QE version

For integration into the machine control cabinet. Supplied with a digital remote control for all Mag and Demag cycles and for the magnetic power adjustment on 8 levels (available upon request at 220/380/440V, 50/60Hz)



### ST version

Self-contained push-button for Mag and Demag cycles with magnetic power adjustment on 3 levels (available at 220V, 50/60Hz)

Model	Dimensions				Weight	
	a (mm)	a (in)	b (mm)	b (in)	(kg)	(lbs)
MDS 153	150	5,91	300	11,81	60	27
MDS 154	150	5,91	400	15,75	79	36
MDS 203	200	7,87	300	11,81	79	36
MDS 204	200	7,87	400	15,75	106	48
MDS 205	200	7,87	500	19,69	132	60
MDS 304	300	11,81	400	15,75	159	72
MDS 305	300	11,81	500	19,69	198	90
MDS 306	300	11,81	600	23,62	238	108
MDS 406*	400	15,75	600	23,62	317	144

Thickness c: 55 mm - (2.16 in)

\*) Available only with "QE" control unit.

All data are drawn and checked with maximum care. We do not charge any responsibility for possible mistakes or omissions. We reserve the right to bring up any modification connected with the technological development.

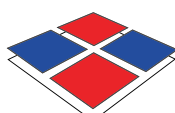

Headquarters

Safety through power  
**TECNOMAGNETE®**

TECNOMAGNETE S.p.A.  
Via Nerviano, 31 - 20020 Lainate (MI) - ITALY  
Tel. +39+02.937.591 - Fax +39+02.935.708.57  
<http://www.tecnomagnete.com>

Subsidiaries:

France: TECNOMAGNETE S.A.R.L.  
Germany: TECNOMAGNETE GmbH  
Japan: TECNOMAGNETE Ltd  
Sweden: TECNOMAGNETE AB  
P.R. China: TECNOMAGNETE R.O.  
USA: TECNOMAGNETE Inc.

PROMOTECH Sp. z o.o.

ul. Elewatorska 23/1,15-620 BIAŁYSTOK, POLAND  
tel. (+48 85) 678-34-26, fax (+48 85) 662-78-77  
e-mail: [marketing@promotech.eu](mailto:marketing@promotech.eu) [www.promotech.eu](http://www.promotech.eu)

MDS-ING/2005-31/03