

PIPE POSITIONER PRO 610 SEG TIG

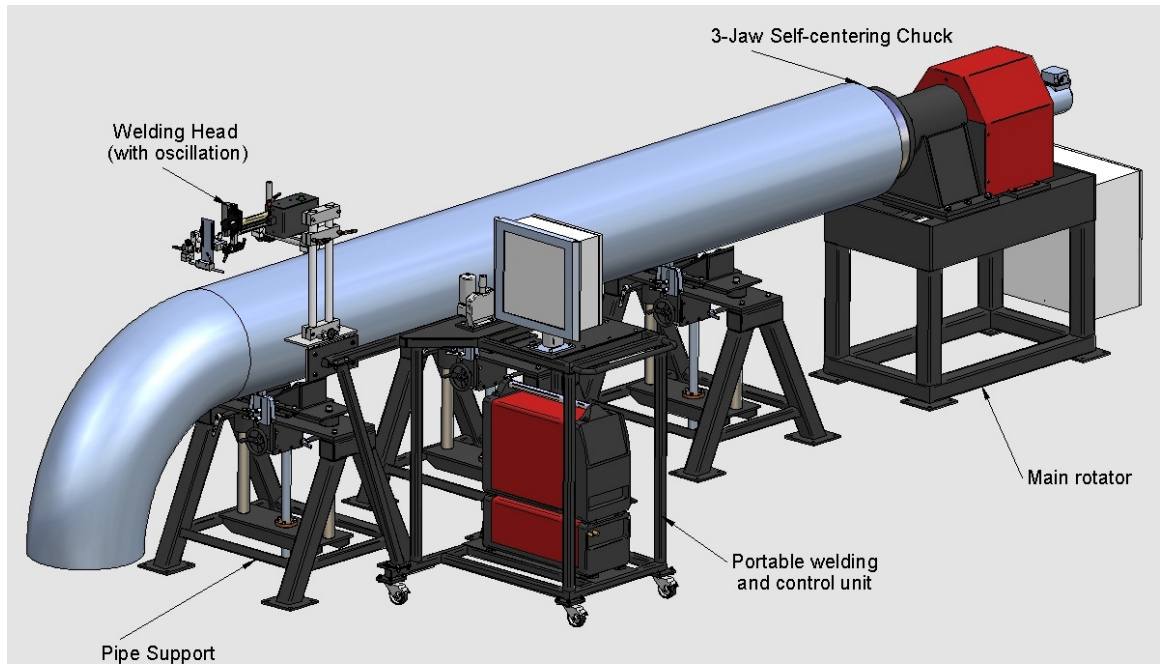

TECHNICAL DATA:

Chuck load capacity	
Max overhung length	59" (1500 mm)
Max overhung weight	198 lbs (90 kg)
Pipe support load capacity	660 lbs (300 kg)
Pipe length with pipe supports*	up to 236 " (6000 mm)
Rotation speed	0,03 – 1,12 [RPM]
Diameter range	4.5 – 24" (114,3 – 610 mm)
Voltage	3 x 400[V]
Frequency	50[Hz]
Weight of main rotator	1025 lbs (465 kg)
Weight of pipe support	320 lbs (145 kg)
Drive unit	Lenze synchronous 3-phase motorgear
Pipe clamping device	3-jaw self-centering chuck 500

* To be customized. Number of pipe supports can vary depending on length and/or weight of workpiece.

Welding process: MIG/MAG/TIG – to be specified by customer

Portable welding and control unit: customized.

Control unit: Servo PLC HMI with touch screen.

Welding source: – to be specified by customer.

PROMOTECH Sp. z o.o.

ul. Elewatorska 23/1, 15-620 BIAŁYSTOK, POLAND
tel. (+48 85) 678 34 05, fax (+48 85) 662-78-77
marketing@promotech.eu www.promotech.eu