

PRO 10 PB PORTABLE PIPE BEVELLER

PRO 10 PB pipe beveling machine is designed for portable use in pipe machining operations.

It can be used efficiently by single operator. It is a typical heavy duty ID mounted pipe beveller.

Self-centering expandable mandrels provide quick and proper alignment to a pipe or a tube prior to machining operations.

PRO 10 PB is able to bevel, face off, chamfer and counterbore, making all these weld prep operations quick and simple.

Depending on users preferences and on site conditions PRO 10 PB machine can be operated with a high quality powerful pneumatic motor or top quality, high torque electric motor.

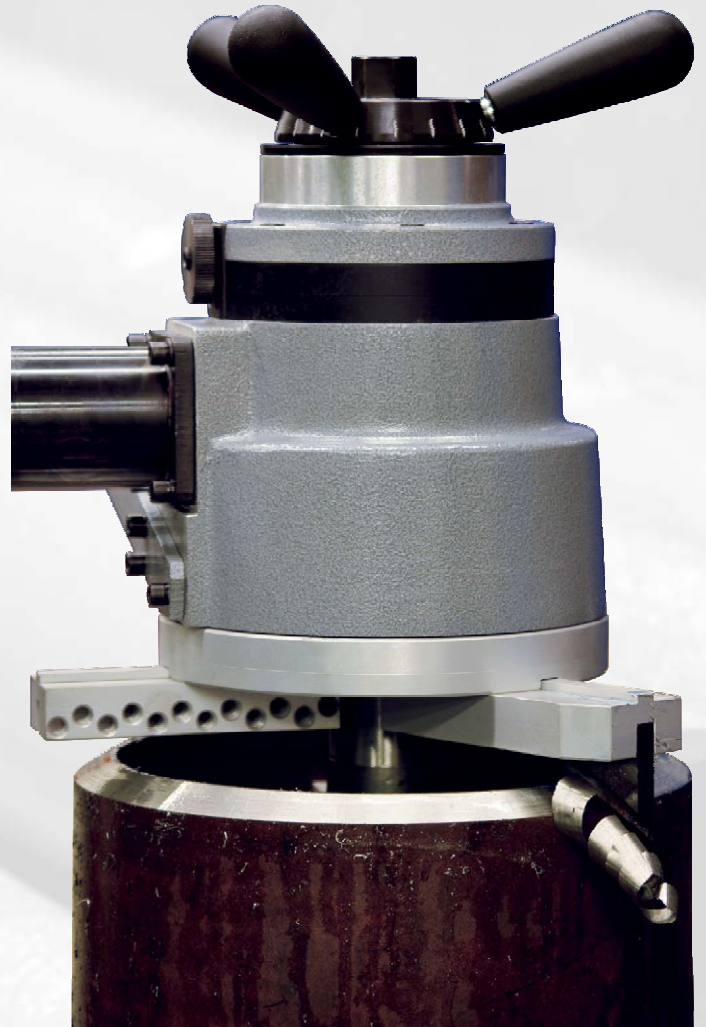

Technical specifications:

Pipe machining range*:

- Min. ID 38mm
- Max ID 365 mm
- Wall thickness: up to 15mm

* optional equipment required

Standard tool bits for various machining operations:

- Beveling
- Facing
- Counterbore and ID chamfer
- J-bevel

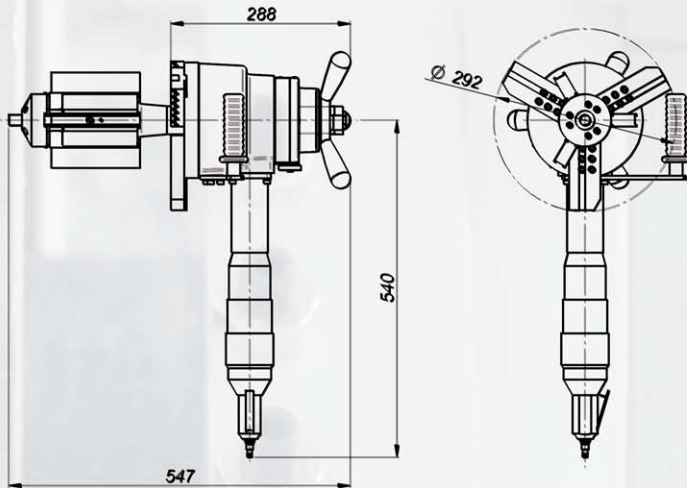

Pneumatic motor: 1,5 kW
Power Requirements: 1750 l/min at 630 kPa
Headstock speed range: 5 to 18 rpm

UKS-0200-10-00-00-1:
PRO 10 PB with pneumatic motor

Electric motor: 1.8 kW
Supply: 115V/60Hz or 230V/50 Hz
Headstock speed range: 14 to 32 rpm

UKS-0200-10-20-02-1:
PRO 10 PBE with electric motor 230V 50/60Hz

UKS-0200-10-10-02-1:
PRO 10 PBE with electric motor 115V 60Hz

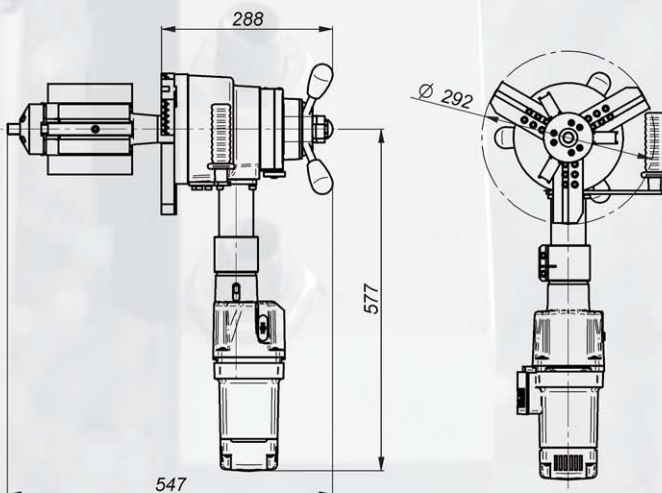

Standard shipping set:

- PRO 10 PB (without tool bits)
- Metal box
- Self-centering expandable Mandrel for pipe ID \varnothing 84 – 269mm (3-5/16 – 10-9/16")
- Set of jaws and blocks
- Set of adjustment tools
- Coolant container
- Operator's manual

Tool bits codes:

- NOZ-000019 30° Beveling Tool Bit, Height 37mm [B30/37]
- NOZ-000018 30° Beveling Tool Bit, Height 44mm [B30/44]
- NOZ-000020 37.5° Beveling Tool Bit, Height 44mm [B375/44]
- NOZ-000015 37.5° Beveling Tool Bit, Height 54mm [B375/54]
- NOZ-000021 45° Beveling Tool Bit, Height 54mm [B45/54]
- NOZ-000017 0° Facing Tool Bit, Height 30mm [F0/30]
- NOZ-000023 30° Internal Beveling Tool Bit, Height 44mm [IB30/44]
- NOZ-000025 30° Internal Beveling Tool Bit, Height 54mm [IB30/54]
- NOZ-000024 37.5° Internal Beveling Tool Bit, Height 54mm [IB375/54]
- NOZ-000026 45° Internal Beveling Tool Bit, Height 54mm [IB45/54]
- NOZ-000001 15° Internal Calibration Tool Bit, Height 55mm [IC15/55]
- NOZ-000022 15° J-Beveling Tool Bit, Height 50mm, Radius 2mm [J15/50/R2]
- NOZ-000016 20° J-Beveling Tool Bit, Height 50mm, Radius 8mm [J20/50/R8]



Beveling Tool Bits

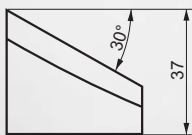

B30/37

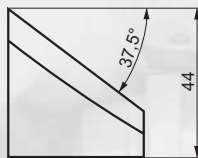

B375/44

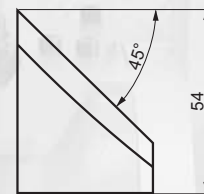

B45/54

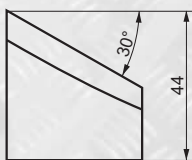

B30/44

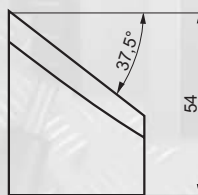

B375/54

Internal Beveling Tool Bits

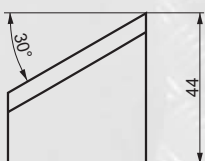

IB30/44

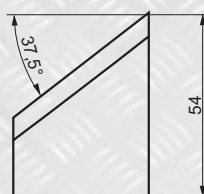

IB375/54

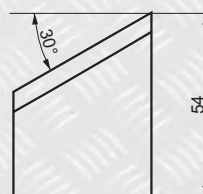

IB30/54

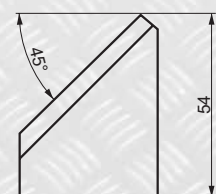

IB45/54

J-Beveling Tool Bits

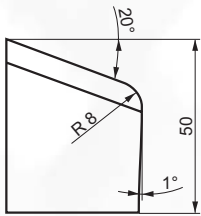

J20/50/R8

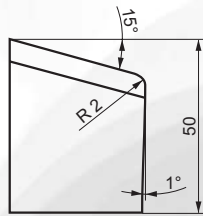

J15/50/R2

ID Chamfer Tool Bit

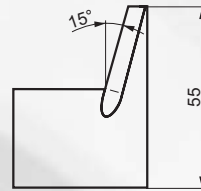

IC15/55

Facing Tool Bit

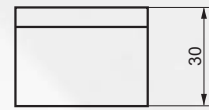

F0/30

Custom made versions of tool bits also available on request.
Tool bits could also be coated to increase their durability.

Additional equipment:

- ZSP-0200-05-00-00-2 Small expanding mandrel set incl. jaws I-IV for pipe ID \varnothing 38 – 86mm (1-1/2 to 3-3/8")
- ZST-0200-13-00-00-1 Extension set for ID \varnothing up to 365mm (14") incl. 3 steel tool holders and jaws 7-12, delivered in metal box
- PRK-0447-00-00-00-2 Flange facing attachment with cutting capacities 90 to 508mm (3-9/16" to 20"), delivered in metal box
- PRK-0463-00-00-00-1 Oval attachment set incl. large mandrel for pipe ID \varnothing 126 – 296mm (5 to 11-5/8"), delivered in metal box
- TRZ-0200-50-00-00-0 Large expanding mandrel for pipe ID \varnothing 126 – 296mm (5 to 11-5/8") with standard jaws, and pipe ID \varnothing 219 – 392mm (8-5/8 to 15-7/16") with optional extension set
- ZST-000021 Air preparation set
- ZST-0200-12-00-00-0 Electric motor set 230V
- ZST-0200-12-00-00-1 Electric motor set 115V US plug
- ZST-0200-12-00-00-2 Electric motor set 115V UK plug
- Tool bits



Air preparation set



All information is subject to change without further notice version 02/2010

More information about accessories and spare parts is available at www.promotech.eu

PROMOTECH Sp. z o.o.
ul. Elewatorska 23/1, 15-620 BIAŁYSTOK, POLAND
tel. (+48 85) 678 34 05, fax (+48 85) 662-78-77
marketing@promotech.eu www.promotech.eu

Your local dealer:

